

# Mass of a chemical element

- **Isotopic mass:**

Exact mass of an isotopic atom  ${}^A\text{X}$

${}^1\text{H}= 1.00787825 \text{ Da}$ ;  ${}^{15}\text{N}=15.0001 \text{ Da}$ ;  ${}^{235}\text{U}=235.044 \text{ Da}$ .

- **Monoisotopic mass (Mm,  $A_0$ ):**

Mass of the **most abundant** isotope

$\text{H}= 1.00787825 \text{ Da}$ ;  $\text{N}=14.0031 \text{ Da}$ ;  $\text{U}=238.050 \text{ Da}$

- **Nominal mass (Nm):**

**Integer mass** of the most abundant stable isotope:

$\text{H}=1$ ,  $\text{N}=14$ ,  $\text{U}=238 \text{ Da}$

# Mass of a molecule

is the **sum of masses** of all atoms:  $XM = \sum_i n_i \cdot X m_i$

$n_i$  – number of  $i$ -th chemical element;  
 $m_i$  – mass of the  $i$ -th chemical element;  
 $X$  – type of the mass ( $M_0$ , N, W).

**H<sub>2</sub>O**:  $i=1, 2$ ;  $n_1=2$ ,  $n_2=1$ ;

$Mm_1=1.007878$  Da,  $Mm_2=15.994915$  Da

$Nm_1= 1$  Da,  $Nm_2=16$  Da

- **Monoisotopic mass (MM,  $M_0$ )**:  $M_0 = \sum_{i=1}^l n_i A_0^i$

Mass of the molecule with all **most abundant** isotopes:

$H_2O = {}^1H_2{}^{16}O = 18.010565$  Da;  $H_2O^+ = 18.010002$  Da ( $m_e = 5.4858 \cdot 10^{-4}$  Da)

- **Nominal mass (NM)**: **Integer mass** of the molecule with all most abundant stable isotopes (**nearest** integer of MM):  $H_2O = 18$  Da,

- **Average mass or Molecular weight (MW)**:

Weighted **average** mass over all natural isotopes of all atoms of the molecule.

## How to calculate Average mass (MW) ?

The mass calculated using a weighted average of the natural isotopes for the atomic mass of each chemical element

$$MW = \sum_{i=1}^l n_i A_r^i$$

$A_r^i$  - average atomic mass (atomic weight);

$m_k^i$  - mass of  $k$ -th isotope of  $i$ -th chemical element;

$\alpha_k^i$  - isotopic abundance of  $k$ -th isotope of  $i$ -th chemical element;

$n_i$  - number of  $i$ -th chemical element;

$l$  - number of different chemical elements

CO<sub>2</sub>:  $M_0 = 12 + 15.995 \cdot 2 = 43.990$  Da; NM= 44 Da;

MW=12.011+ 15.9994·2= 44.0098 Da

$$MW = \sum_{i=1}^l n_i A_r^i.$$

CCl<sub>4</sub>: <sup>12</sup>C=12 (98.9%), <sup>13</sup>C= 13.0034; <sup>35</sup>Cl =34.9688 (75.7%), <sup>37</sup>Cl=36.9659 (24.3%);  $n_C=1, n_{Cl}=4$

$M_0 = 12 + 34.96885 \cdot 4 = 151.8754$  Da

MW= (12·0.989+13.0034·0.011) + (34.9688·0.757+36.9659·0.243)·4 =153.8225 Da

$$MW = \sum_{i=1}^l \sum_k n_i m_k^i \alpha_k^i$$

# Some definitions

**Isobars:** Ions with the same nominal mass.

**Example:** CO and N<sub>2</sub> (NM= 28 Da)

## Isotopologues

- Isotopologues are molecules that differ only in the **isotopic composition** of one or more of their atoms
- Isotopologues have *different* mass

## Isotopic distribution

- Relative abundance of all natural isotopologues of the same molecule. = Relative intensities of mass peaks in an MS spectrum of single compound.

*Isotopic distribution carries two pieces of information about chemical composition of a molecule*

## Examples:

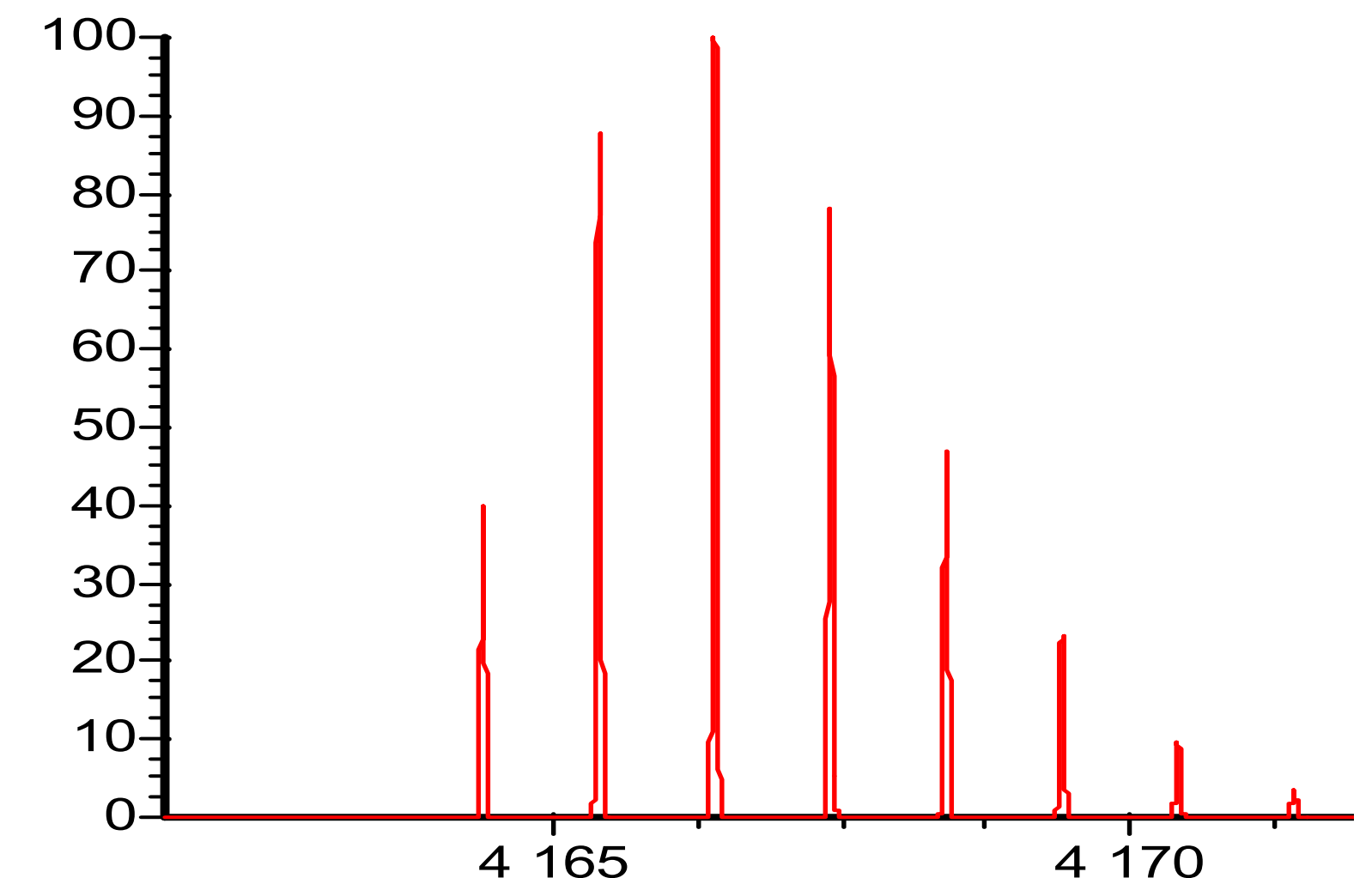
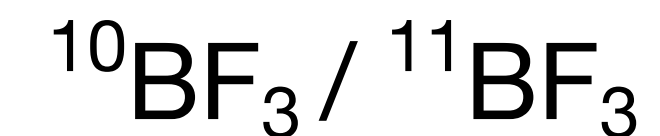
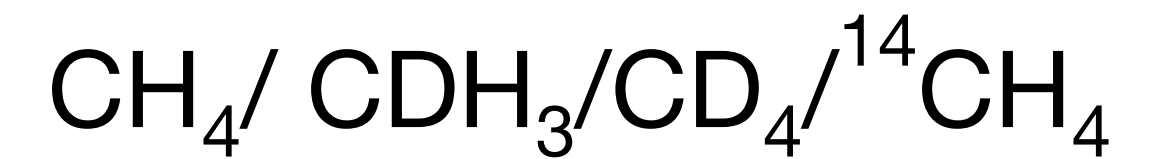

# Natural isotopic abundance of some elements

Element	A		A+1		A+2		Element type
	Mass	%	Mass	%	Mass	%	
H	1	100	2	0.015			A
C	12	100	13	1.1			A+1
N	14	100	15	0.37			A+1
O	16	100	17	0.04	18	0.20	A+2
F	19	100					A
Si	28	100	29	5.1	30	3.4	A+2
P	31	100					A
S	32	100	33	0.79	34	4.4	A+2
Cl	35	100			37	32.0	A+2
Br	79	100			81	97.3	A+2
I	127	100					A

- Stable isotopes only
- For most of large organic molecules isotopic peaks due to carbon are the most abundant.

# Isotopic distribution due to $^{13}\text{C}$

## Observations

- $A$  peak (monoisotopic) is the most abundant.
- Relative intensity of  $A+1$  peak is higher than natural abundance of  $^{13}\text{C}$ .
- $A+2$  peaks is present, although there are only two stable isotopes.

➤ Why ?

➤ What can we determine for the chemical composition of the molecule ?

Mass spectrum of a pure compound  
(bar plot)

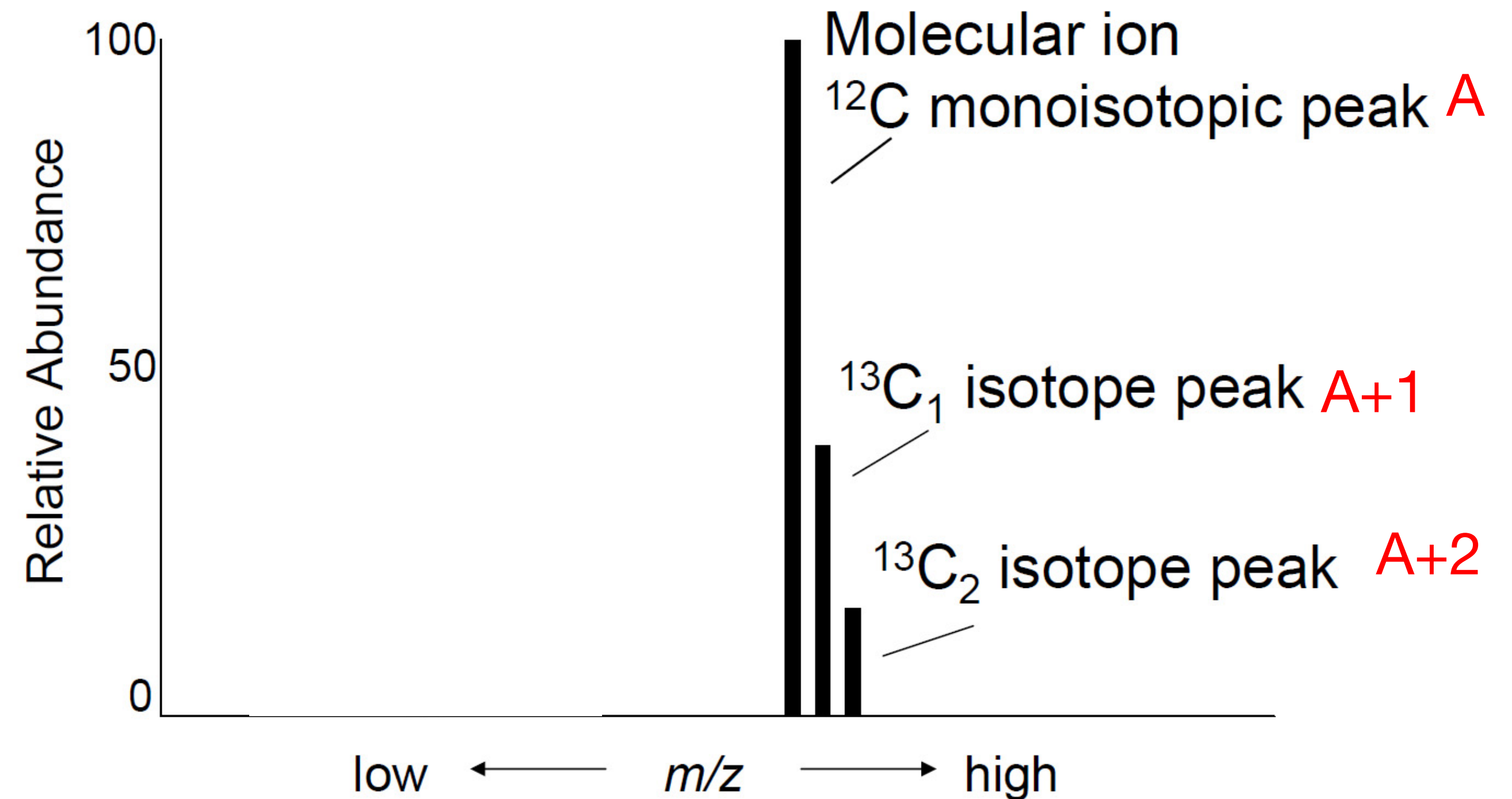

Statistics !

# Calculating a relative isotopic distribution

Consider only carbon isotopes (abundances  $\alpha_{12}= 0.989$  and  $\alpha_{13}= 0.011$ ) for a molecule with  $n$ - number of carbon atoms

Probability for a molecule to have all carbons as  $^{12}\text{C}$   
(Monoisotopic peak **A**):

$$P_A = \alpha_{12}^n$$

Probability for a molecule to have only one  $^{13}\text{C}$   
(First isotopic peak, **A+1**):

$$P_{A+1} = n \cdot \alpha_{13} \cdot \alpha_{12}^{n-1}$$

Probability to have two  $^{13}\text{C}$  atoms (Second isotopic  
peak **A+2**):

$$P_{A+2} = \frac{1}{2} \cdot n(n-1) \cdot \alpha_{13}^2 \cdot \alpha_{12}^{n-2}$$

Probability to have  $m$   $^{13}\text{C}$  atoms  
( $m$ -th isotopic peak, **A+m**):

$$P_{A+m} = \frac{n!}{(n-m)!m!} \cdot \alpha_{13}^m \cdot \alpha_{12}^{n-m}$$

!!! The sum of all probabilities ( $m= 0, \dots, n$ ) is equal to 1.

# Calculating a relative isotopic distribution

Relative intensity of the peak in % for ion with  $m$  number of  $^{13}\text{C}$  and  $n$  total number of carbons:  $I(A+m)$ :

$$I(A+m) = \frac{P_{A+m}}{P_A} \cdot 100\%$$

Note that: 
$$\frac{I_{A+m+1}}{I_{A+m}} = \frac{(n-m)!m!}{(n-m-1)!(m+1)!} \cdot \frac{\alpha_{13}^{m+1}\alpha_{12}^{n-m-1}}{\alpha_{13}^m\alpha_{12}^{n-m}} = \frac{(n-m) \cdot \alpha_{13}}{(m+1) \cdot \alpha_{12}} \approx 0.0111 \cdot \frac{(n-m)}{(m+1)}$$

For  $m=0$  : 
$$\frac{I_{A+1}}{I_A} \approx 0.0111 \cdot n \quad \Rightarrow \quad n_C \approx 90 \cdot I_{A+1}/I_A$$

For  $m=1$  : 
$$\frac{I_{A+2}}{I_{A+1}} \approx 0.0055 \cdot (n-1) \quad \Rightarrow \quad n_C \approx 180 \cdot I_{A+2}/I_{A+1} + 1$$

.....

!!! Number of carbons can be estimated from ratios of observed subsequent isotopic peaks.

*Fit of all intense peaks may improve the accuracy*

# How to calculate an isotopic distribution considering essential isotopes of all elements

1. Start from the molecular formula, and calculate the accurate masses for all possible isotopic combinations:  $A$ ,  $A+1$ ,  $A+2$ , . . .
  - Do not consider  $^2\text{H}$  and  $^{17}\text{O}$  isotopes — they are not sufficiently abundant.
  - Do not consider any more than 3-5 isotope peaks, unless explicitly asked.
2. For each isotopic peak ( $A$ ,  $A+1$ ,  $A+2$ ), calculate the **abundance**  $A$  separately for each chemical element using the following formula:

$$A = \frac{n!}{(a)!(b)!(c)! \dots} (r_1)^a (r_2)^b (r_3)^c \dots$$

where  $n$  is the number of atoms of a given element;  $a$ ,  $b$ , and  $c$  are the numbers of each type of isotopes of this element ( $a+b+c=n$ ), and  $r_1$ ,  $r_2$ ,  $r_3$  are the abundances of each isotope.

3. For each isotopic peak ( $A$ ,  $A+1$ ,  $A+2$ ), calculate the total abundance (combination of all participating elements) using the following formula:

$$\text{Total } A = A(\text{element 1}) \times A(\text{element 2}) \times A(\text{element 3}) \dots$$

# Isotope spacing: multiple charges

- As the charge state increases, the spacing between isotope peaks decreases.

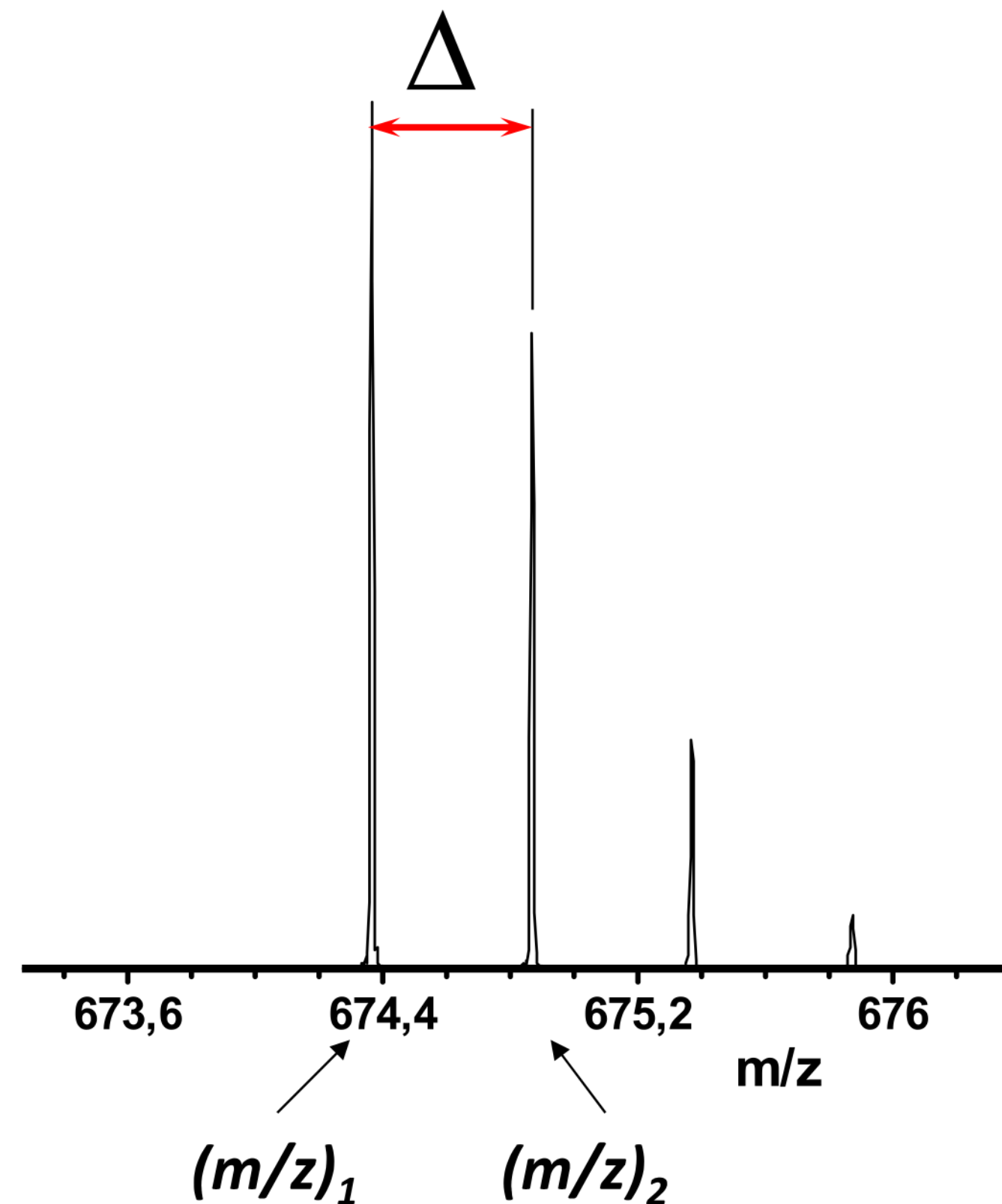

$$\begin{aligned}\Delta &= (m/z)_2 - (m/z)_1 \\ &= (m_2/z) - (m_1/z) \\ &= (m_2 - m_1)/z = 1/z\end{aligned}$$

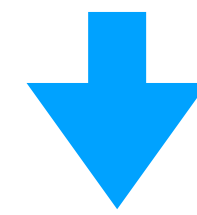

$$z = 1/\Delta$$

$\Delta = 1 \text{ Da}$	$z=1$
$\Delta = 0.5 \text{ Da}$	$z=2$
$\Delta = 0.33 \text{ Da}$	$z=3$
$\Delta = 0.25 \text{ Da}$	$z=4$

- Resolution needs to be increased to make fine structure visible for multiply-charged ions

# Mass accuracy

**Mass accuracy:** Difference between the theoretical and experimental masses

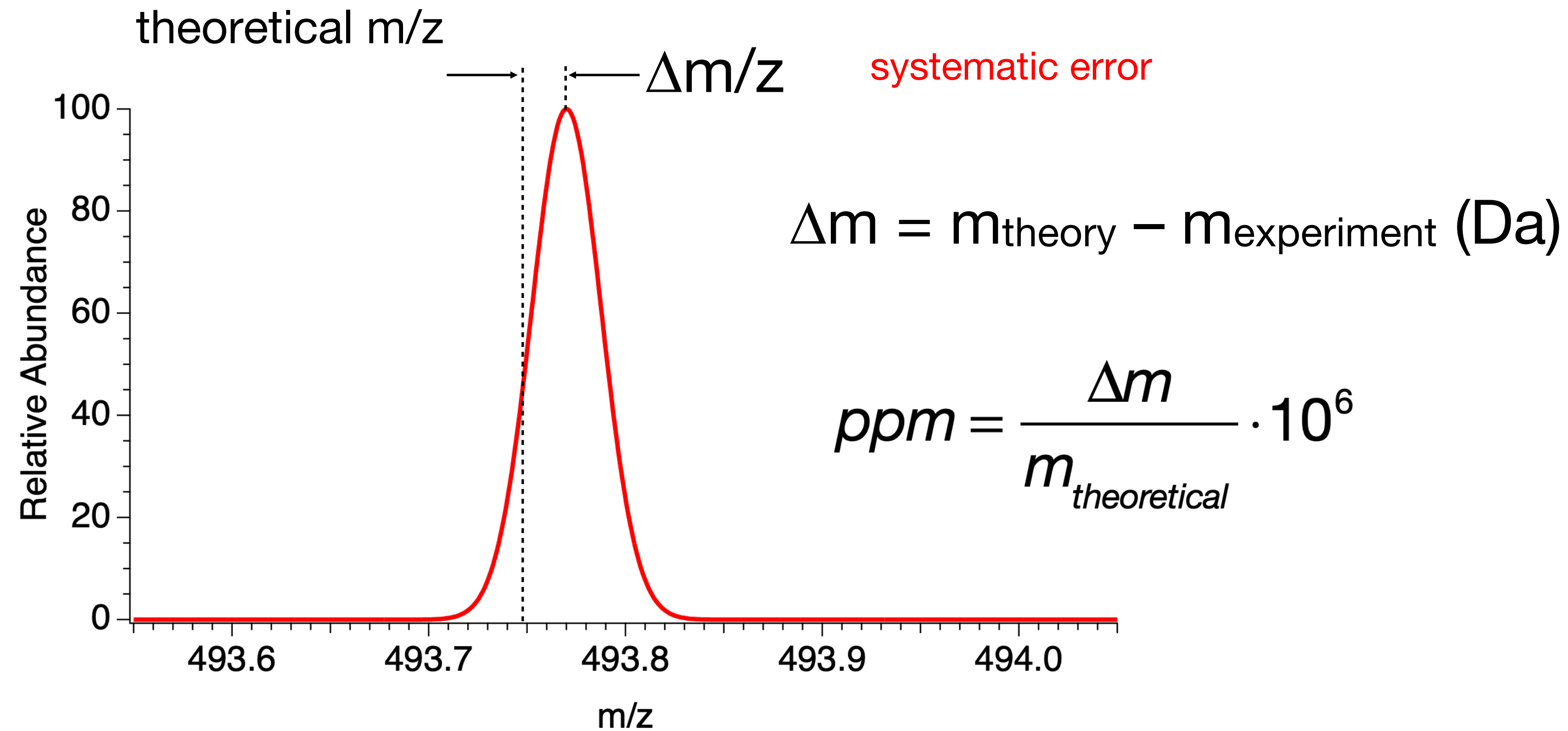

# Precision

*Definition:* Closeness of agreement among a set of repetitive measurements

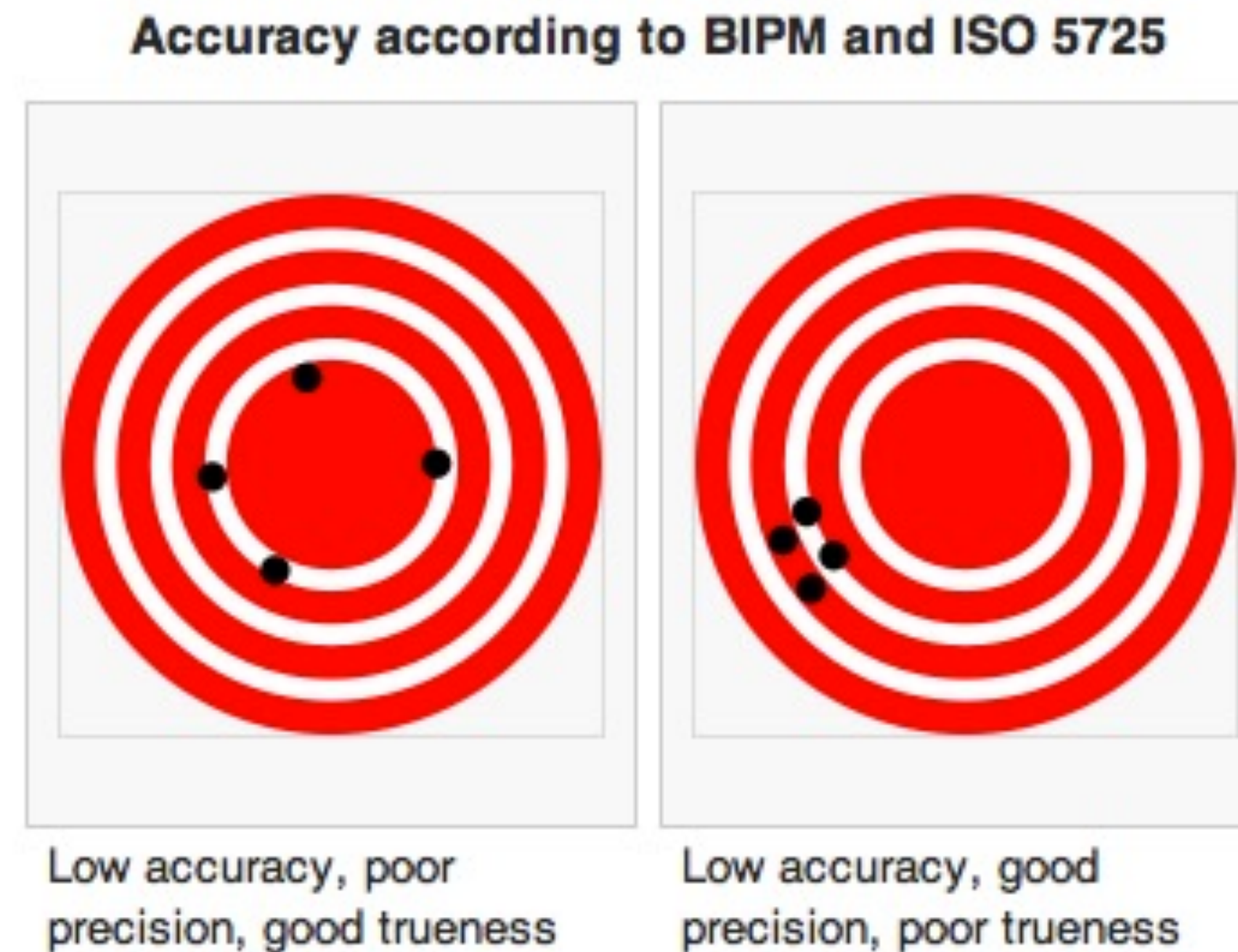

**Repeatability:** *Short term stability of results on the same instrument*

**Reproducibility:** *Long term stability of results on any instrument*

# Resolution

**FWHM** = width of a peak measured at the half of its height;

*Peaks in MS are often of Gaussian shape (statistics)*

Raley criteria of **resolution**:

$$\Delta(m/z) = FWHM;$$

## Definition:

Mass-resolution **R** is the ratio of  $m/z$  over the FWHM of the peak:

$$R = \frac{(m/z)}{FWHM};$$

*Resolution is characteristic of a peak*

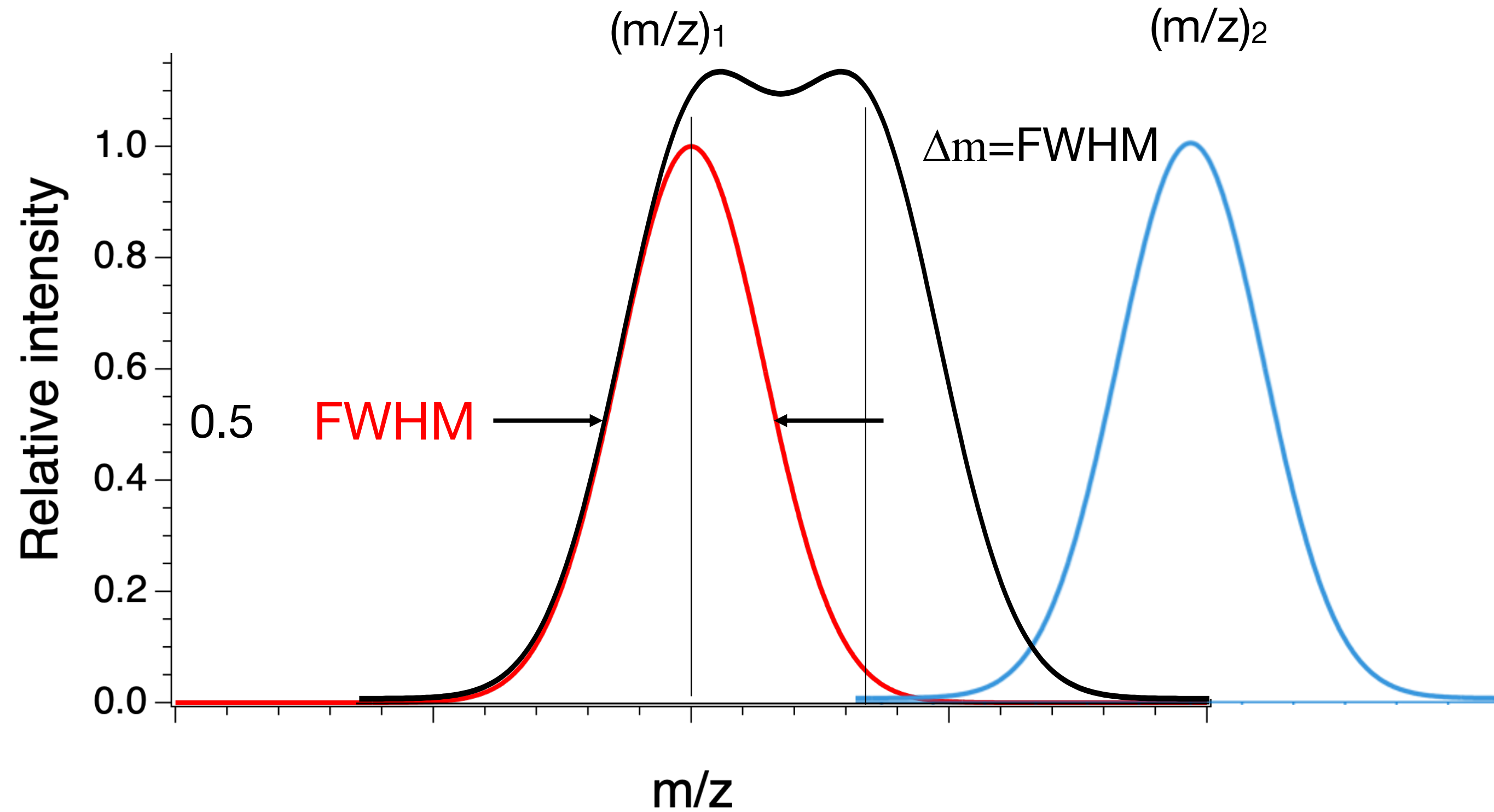

Resolution determines FWHM of a mass-peak:

$$FWHM = \frac{(m/z)}{R};$$

# Resolving power

## Definition:

Resolving power **RP** is the ratio of  $(m/z)$  over the minimum separation of two equal peaks  $\Delta(m/z)$  required for a MS instrument to distinguish them.

*Resolving Power relates to two peaks*

Most popular in MS criteria of RP is **10% valley**:

$$\Delta(m/z) \equiv \Delta_{5\%}(m/z) = 1.8 \cdot FWHM;$$

$$RP_{10\%} = \frac{(m/z)}{\Delta_{5\%}(m/z)} \simeq \frac{(m/z)}{1.8 \cdot FWHM} = 0.56 \cdot R;$$

*RP of an instrument may change with  $m/z$ .*

$$R = 1.8 \cdot RP_{10\%} = 1.8 \cdot \frac{(m/z)}{\Delta(m/z)}.$$

*With this **R** two peaks will be resolved with 10% valley.*

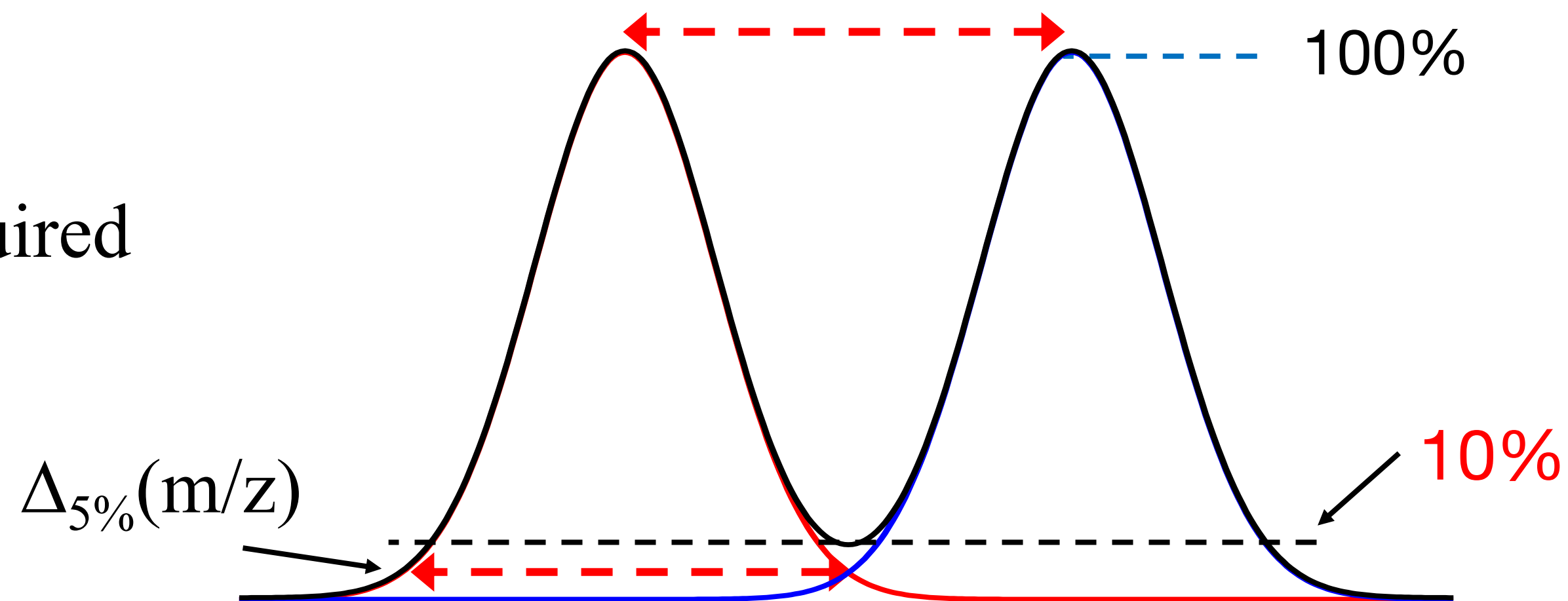

Example:  $\text{CO}^+$  and  $\text{N}_2^+$

$$M_0(\text{CO}^+) = 12.00000 + 15.99492 - 0.00055 = 27.99437$$

$$M_0(\text{N}_2^+) = 2 \times 14.00307 - 0.00055 = 28.00559$$

$$\Delta(m/z) = 0.01122; \quad \text{NM} = 28;$$

$$R = 1.8 \cdot \frac{28}{0.01122} \simeq 4500.$$

*Keep 2 digits only*

# Ionization methods

## Molecular Analysis

- Electron impact ionization (EI)
- Chemical ionization (CI)
- Photoionization (PI)
- Electrospray ionization (ESI)
- Matrix-assisted laser desorption/ionization (MALDI)

## Elemental Analysis

- Thermal desorption
- Spark ionization
- Inductively coupled plasma
- Glow discharge
- Secondary ion mass spectrometry (SIMS)

# Electron impact ionization (EI)

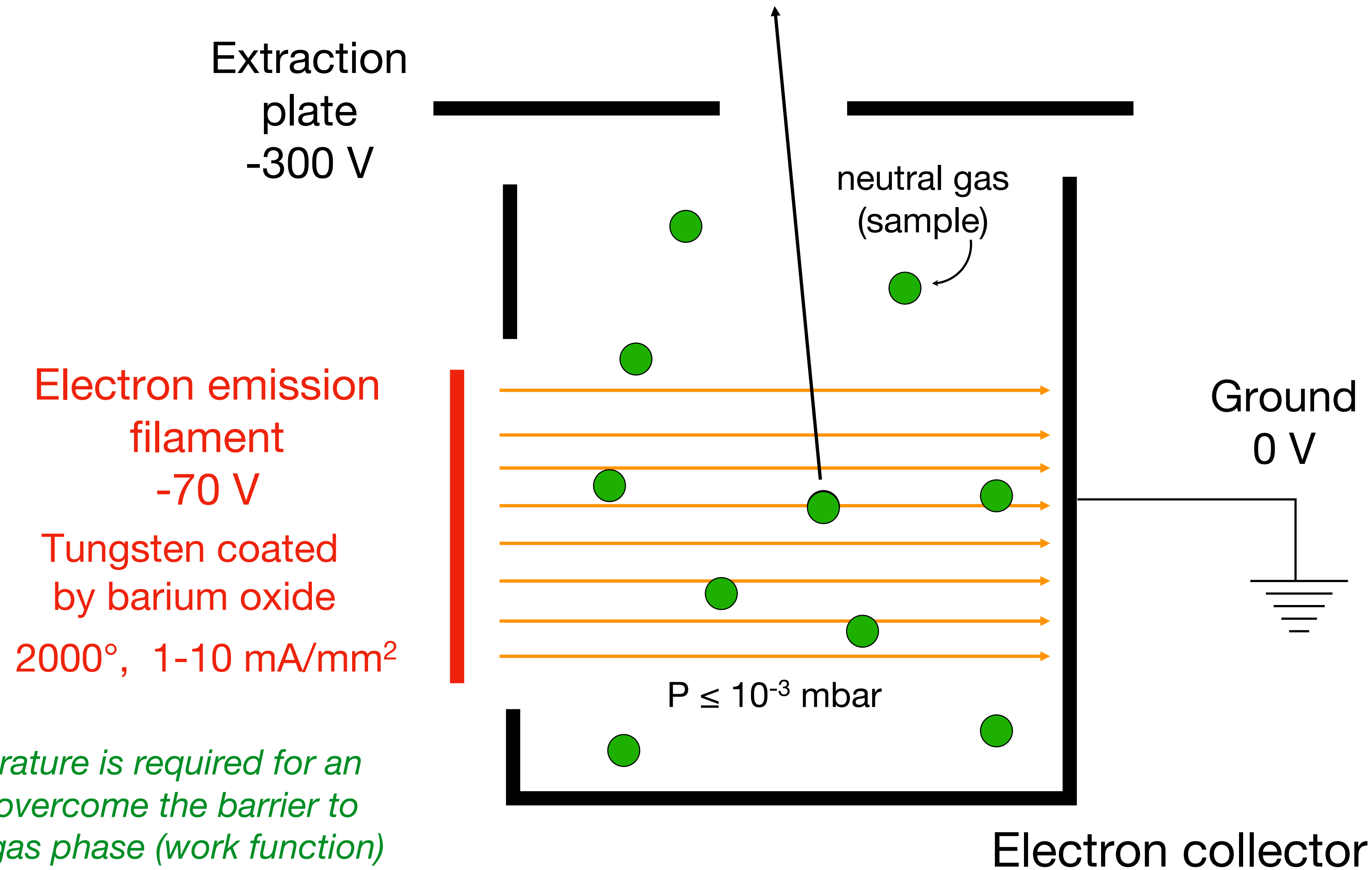

*High temperature is required for an electron to overcome the barrier to get to the gas phase (work function)*

# Electron impact ionization (EI)

- The **ionization potential** is the electron energy that will produce a molecular ion. The **appearance potential** for a given fragment ion is the electron energy that will produce that fragment ion.
- Most mass spectrometers use electrons with an energy of 70 electron volts (eV) for EI.
- Decreasing the electron energy can reduce fragmentation, but it also reduces the number of ions formed.

# Electron energy dependence

Number of ions produced as a function of the electron energy

$$I = \alpha \cdot i \cdot p \cdot V$$

$i$  – filament current

$p$  – pressure

$V$  - volume

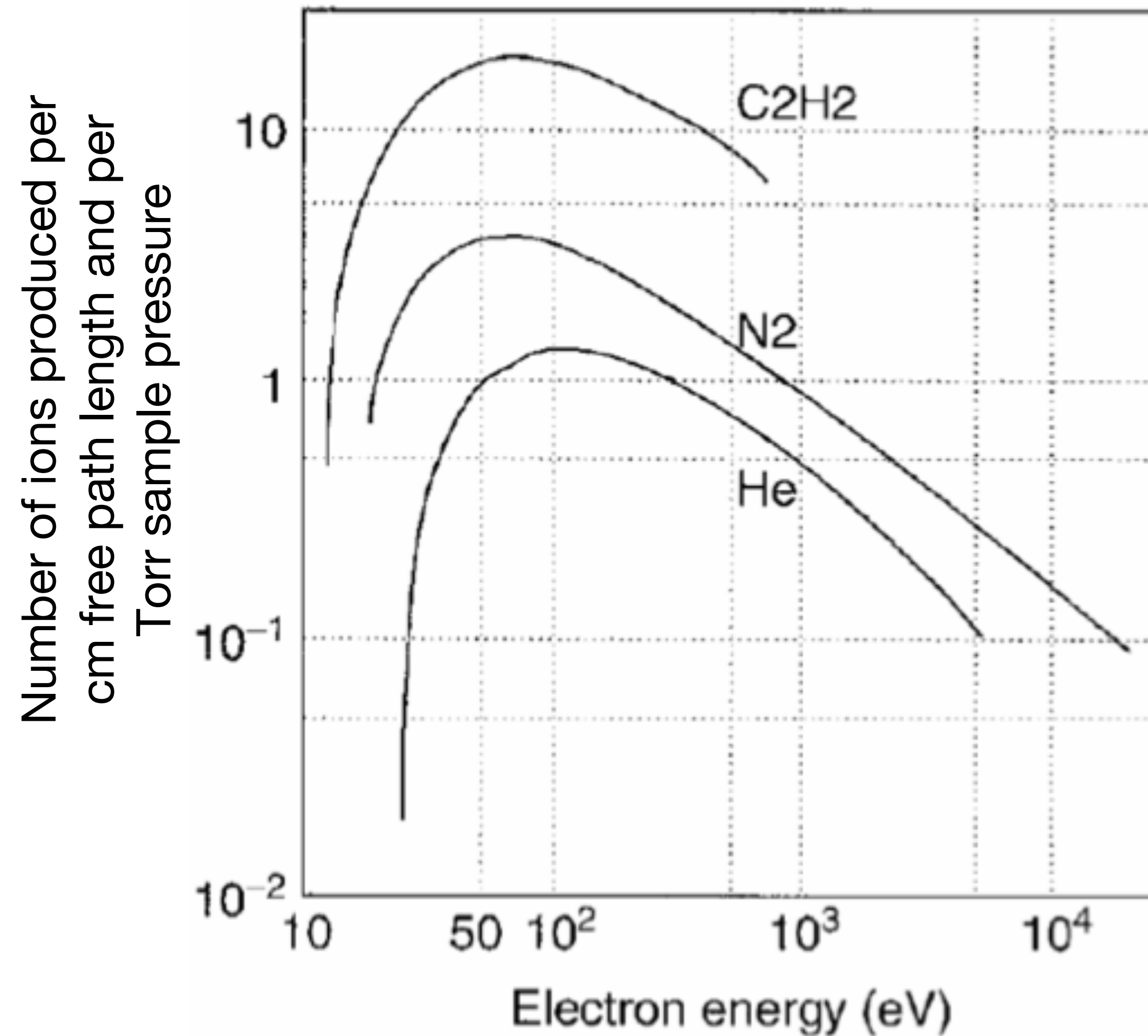

Note the wide maximum at around 70 eV

# Ionization efficiency

Best condition for energy transfer is when the size of an external electron (width of probability) is close to the bond length (“size” of the valent electron).

For organic molecules the average bond length is around  $l \sim 1.4 \text{ \AA}$ . DeBroglie wavelength:  $\lambda = h/mv$

$$E=15 \text{ eV: } \lambda \sim 3 \text{ \AA}$$

$$E=70 \text{ eV: } \lambda \sim 1.4 \text{ \AA}$$

$$E=140 \text{ eV } l \sim 0.7 \text{ \AA}$$

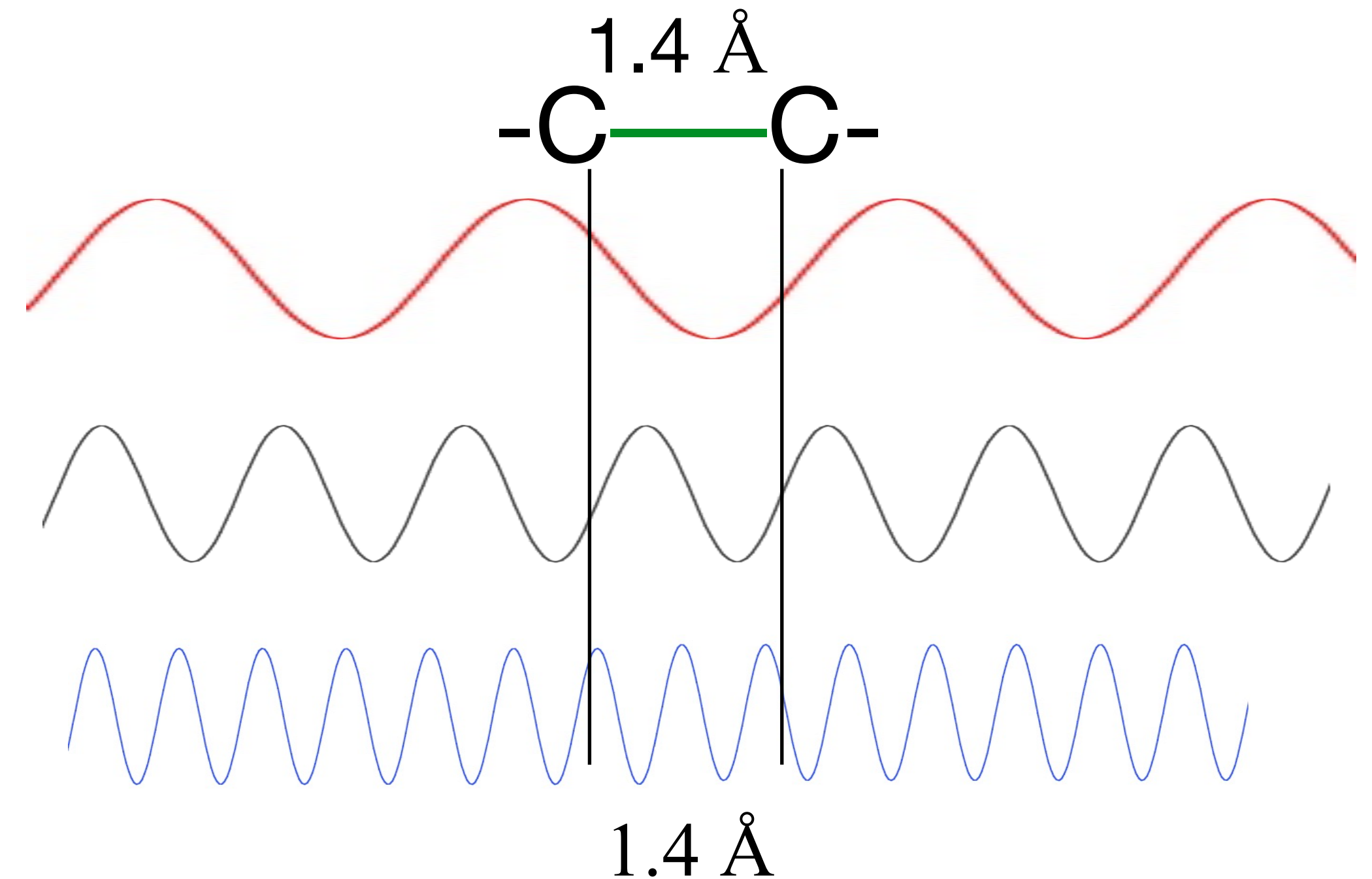

# Electron impact ionization

## Advantages

- Reproducible and well understood
- Extensive fragmentation occurs
- High ionization efficiency
- Universal to all vaporized molecules
- Libraries of EI spectra allow for compound identification and quantification
- Very sensitive: 1 in 1000 molecules ionized

## Disadvantages

- Only positive ions
- Extensive fragmentation occurs
- Radical cations formed
- Sample must be volatile and hence low MW
- Ionization is non-selective
- All vaporized molecules contribute

⇒ Harsh, universal, highly reproducible method for volatile molecules

# Electrospray ionization

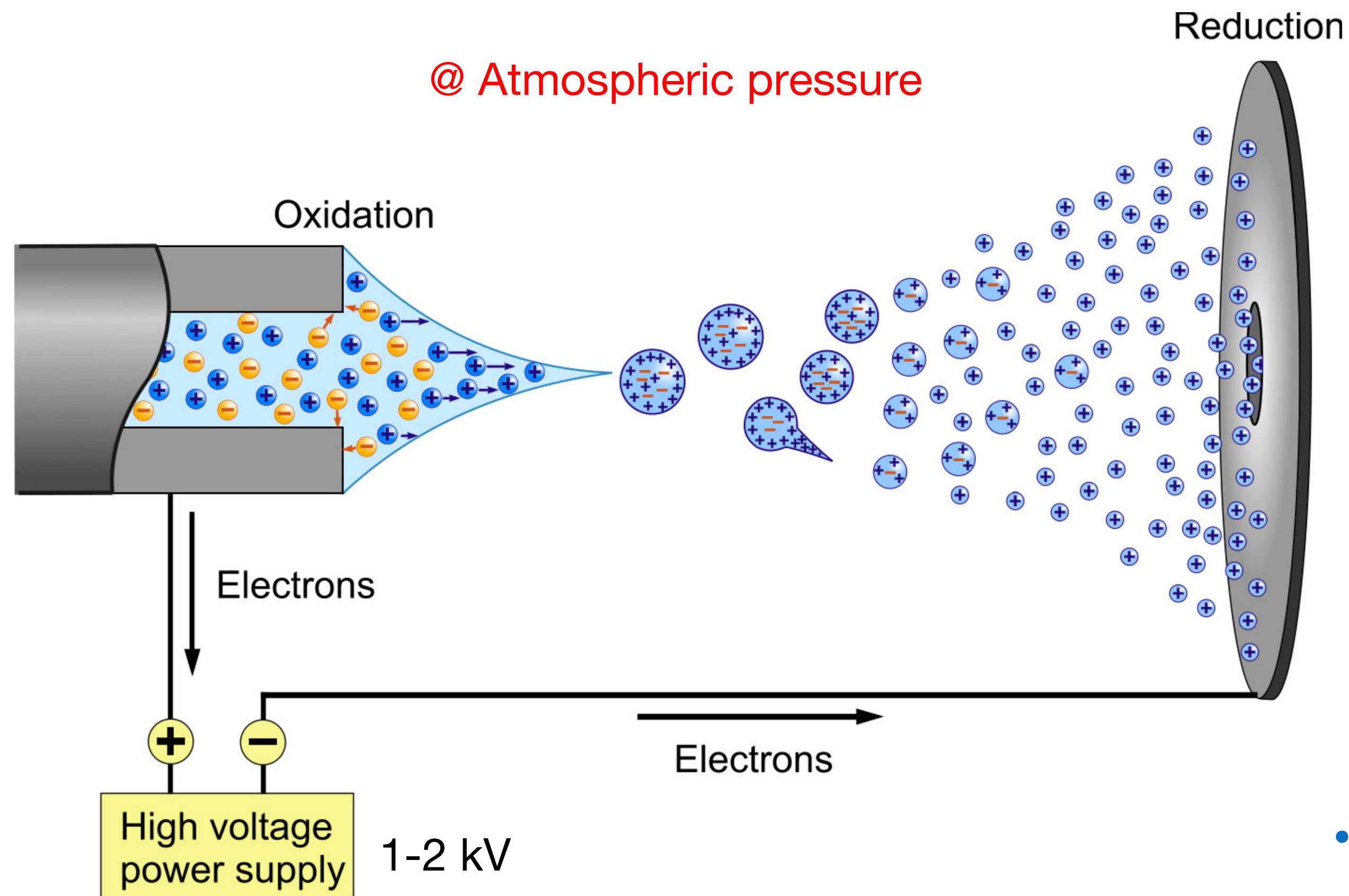

John Fenn  
Nobel Prize  
2002

- Produces multiply-charged ions
- Soft: can retain non-covalent complexes, including solvent-ion and protein-protein.

- Sample is introduced directly from the liquid
- A spray of charged droplets are formed
- Desolvation and breakup of droplets occurs
- Ions emerge from charged droplets
- Ions are sampled from the atmosphere

# Multiple Charging in Electrospray Ionization

When spraying large, biological molecules, ESI tends to produce multiply-charged ions.

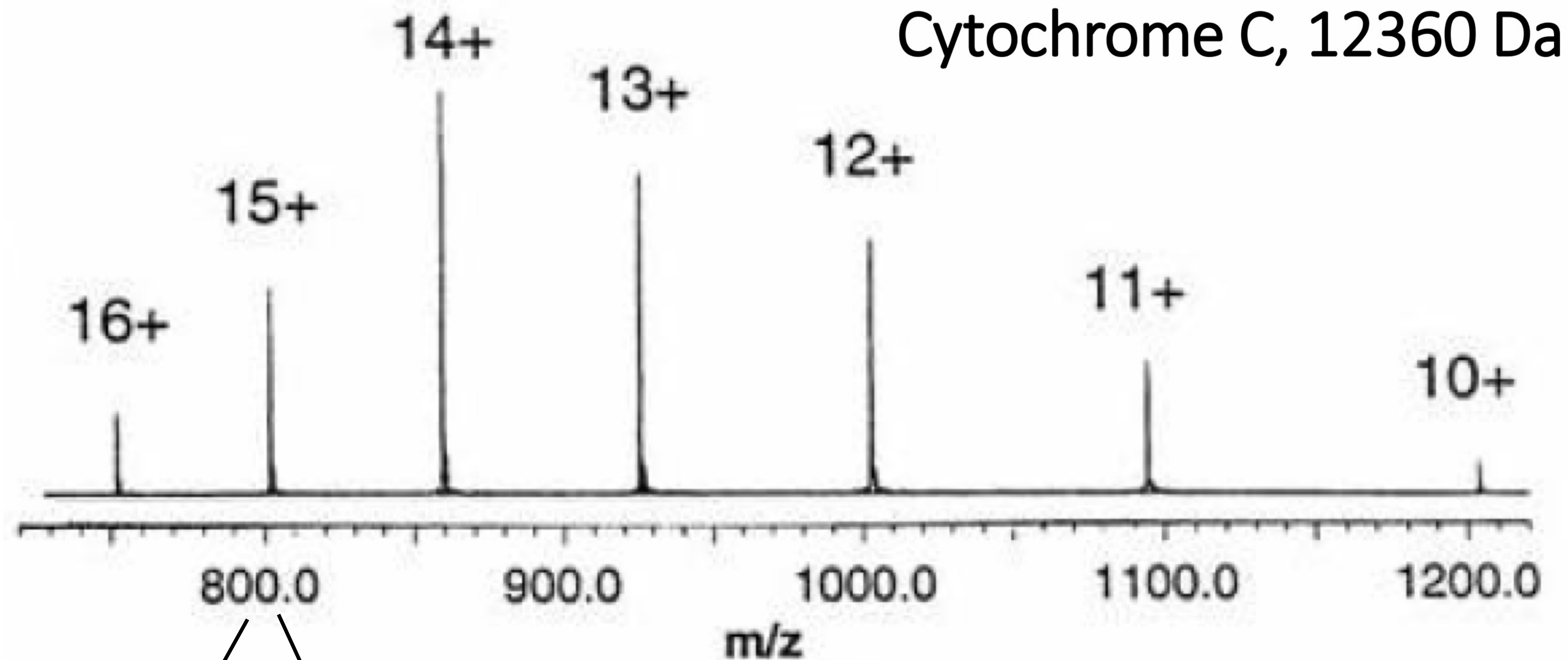

isotope peaks

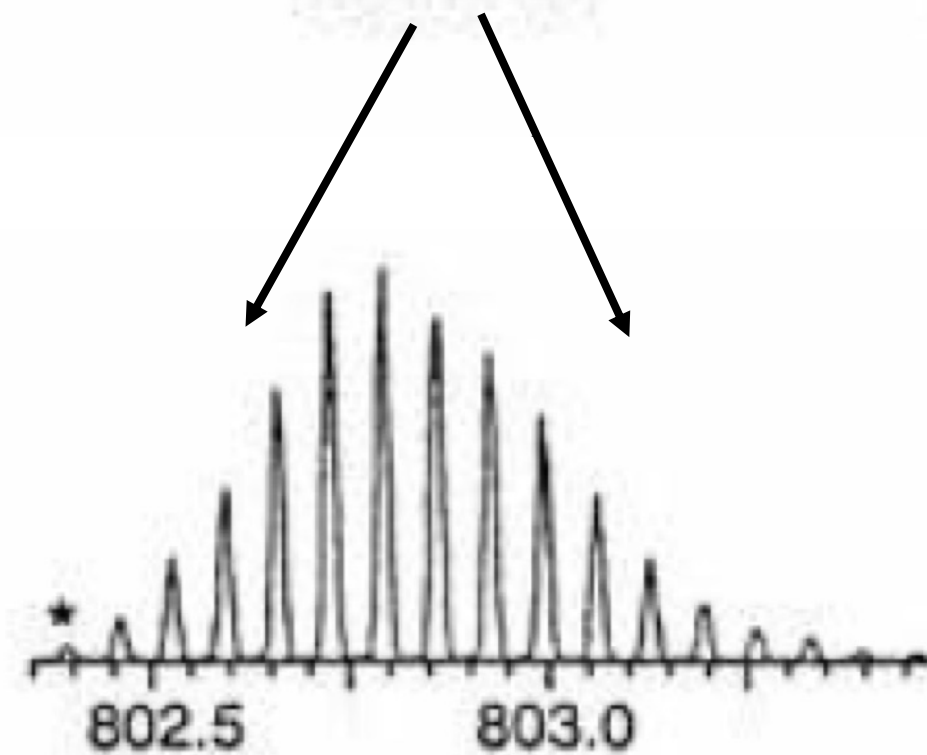

Multiple charge states in ESI allows for MS of heavy molecules in instruments with limited MAX m/z.

# Analysis of multiply charged ions from ESI

## Protein GroES

10.3 kDa

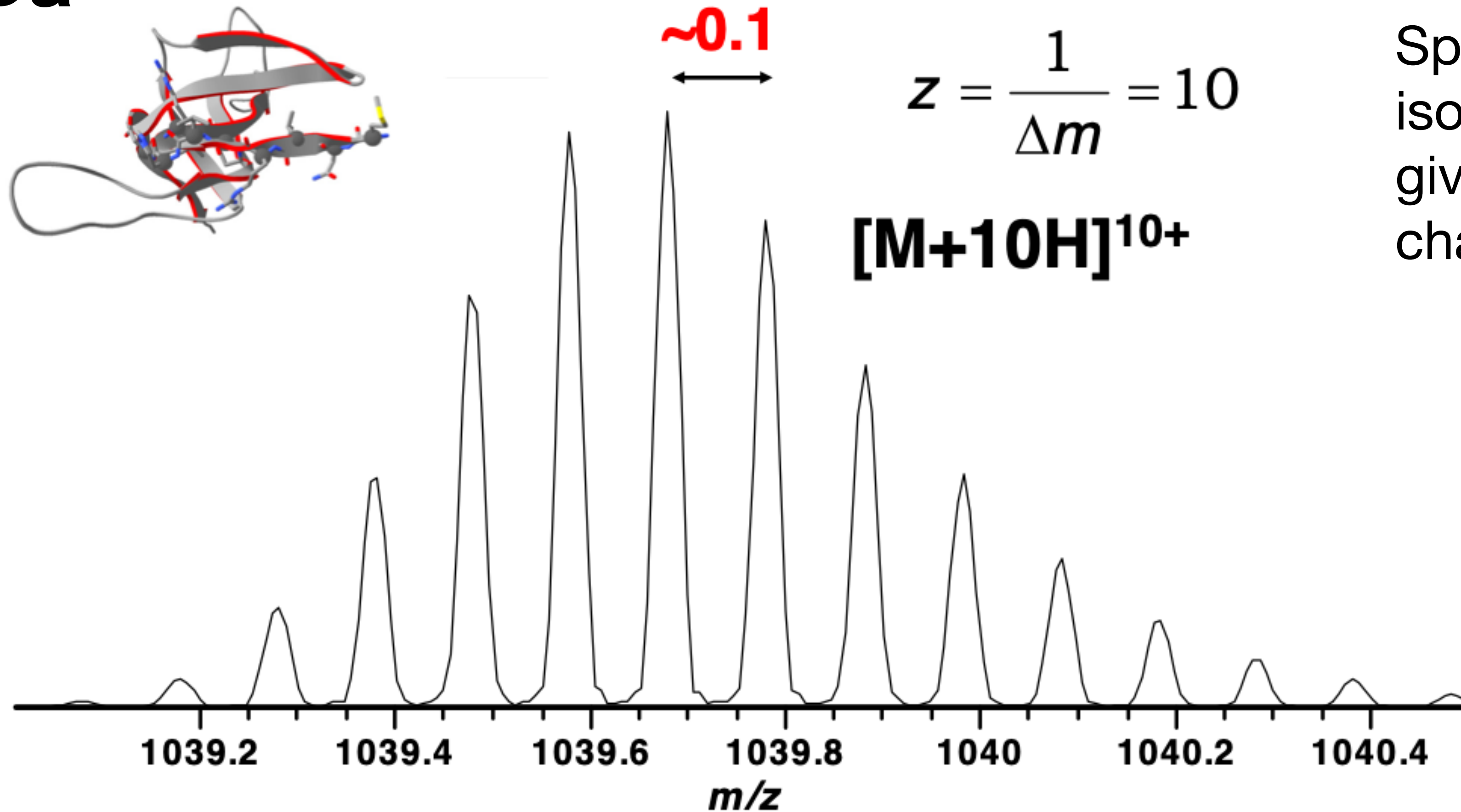

Spacing of isotopic peaks give you the charge state.

# Analysis of multiply protonated ions from ESI

No isotopic distribution !

How to find  $Z$  and  $M$  from charge distribution MS ?

1. Numerate peaks in charge distribution; take any as the first and go to higher  $m/z$ .
2. For any two peaks  $i$  and  $j$  one can write:

$$z_i \cdot m_i = M + z_i \cdot m_p; \text{ and } z_j \cdot m_j = M + z_j \cdot m_p.$$

$M$  –mass of the molecule;

$m$  and  $z$  – mass and charge of an ion

3. Combining and solving for  $z_i$  and  $M$ :

$$z_i = \frac{(j-i) \cdot (m_j - m_p)}{(m_j - m_i)} = \frac{4 \cdot 1124.7}{299.9} = 15.001$$

$$M = z_i(m_i - m_p) = \frac{(j-i) \cdot (m_j - m_p) \cdot (m_i - m_p)}{(m_j - m_i)}$$

$$M = \frac{4 \cdot (1125.7 - 1) \cdot (825.8 - 1)}{(1125.7 - 825.8)} = 12372.8$$

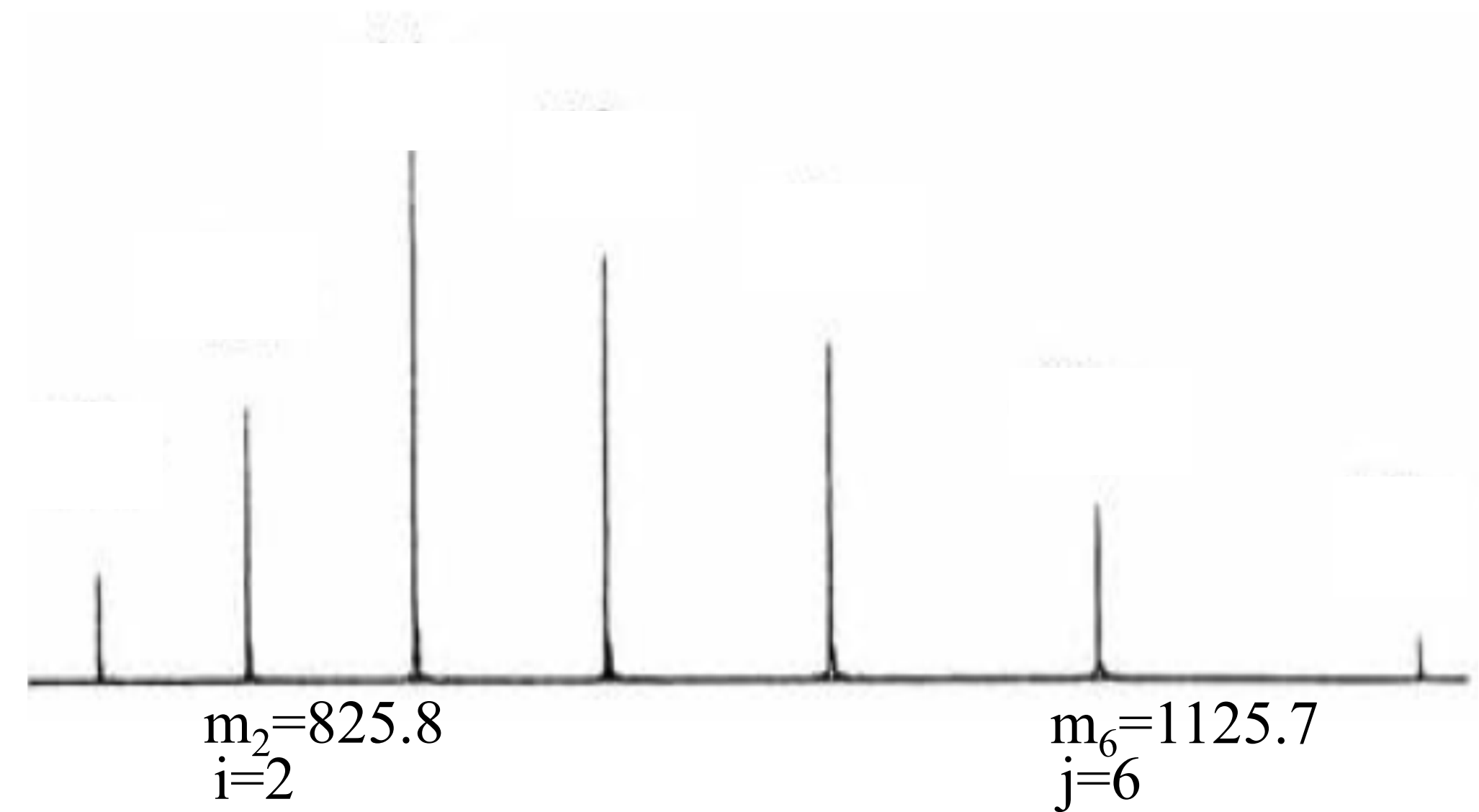

Low-resolution mass spectrum of a protonated molecule produced with ESI

# Analysis of multiply protonated ions from ESI

No isotopic distribution !

How to find  $Z$  and  $M$  from charge distribution MS ?

1. Numerate peaks in charge distribution; take any as the first and go to higher  $m/z$ .
2. For any two peaks  $i$  and  $j$  one can write:

$$z_i \cdot m_i = M + z_i \cdot m_p; \text{ and } z_j \cdot m_j = M + z_j \cdot m_p.$$

$M$  –mass of the molecule;

$m$  and  $z$  – mass and charge of an ion

3. Combining and solving for  $z_i$  and  $M$ :

$$z_i = \frac{(j-i) \cdot (m_j - m_p)}{(m_j - m_i)} = \frac{4 \cdot 1124.7}{299.9} = 15.001$$

$$M = z_i(m_i - m_p) = \frac{(j-i) \cdot (m_j - m_p) \cdot (m_i - m_p)}{(m_j - m_i)}$$

$$M = \frac{4 \cdot (1125.7 - 1) \cdot (825.8 - 1)}{(1125.7 - 825.8)} = 12372.8$$

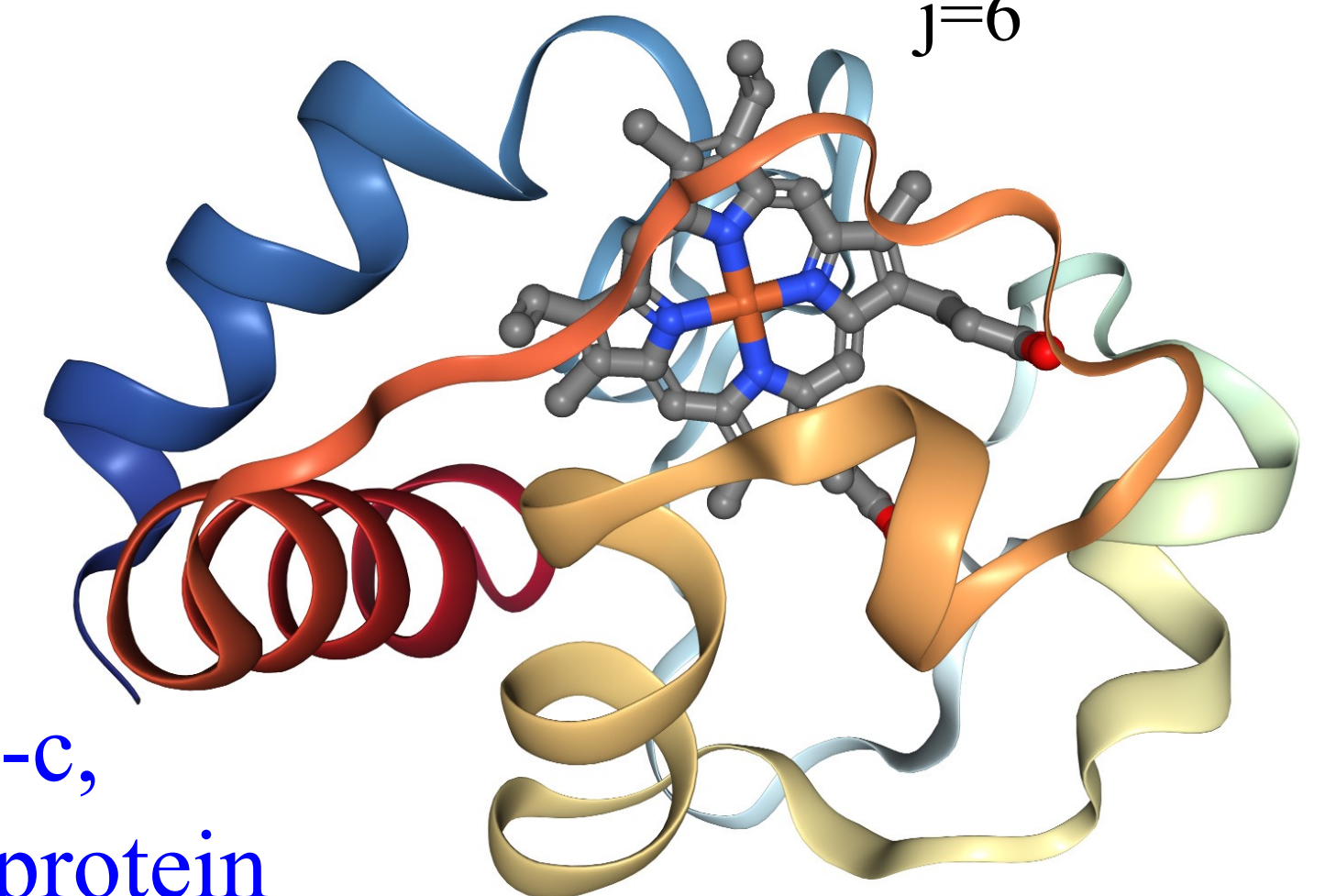
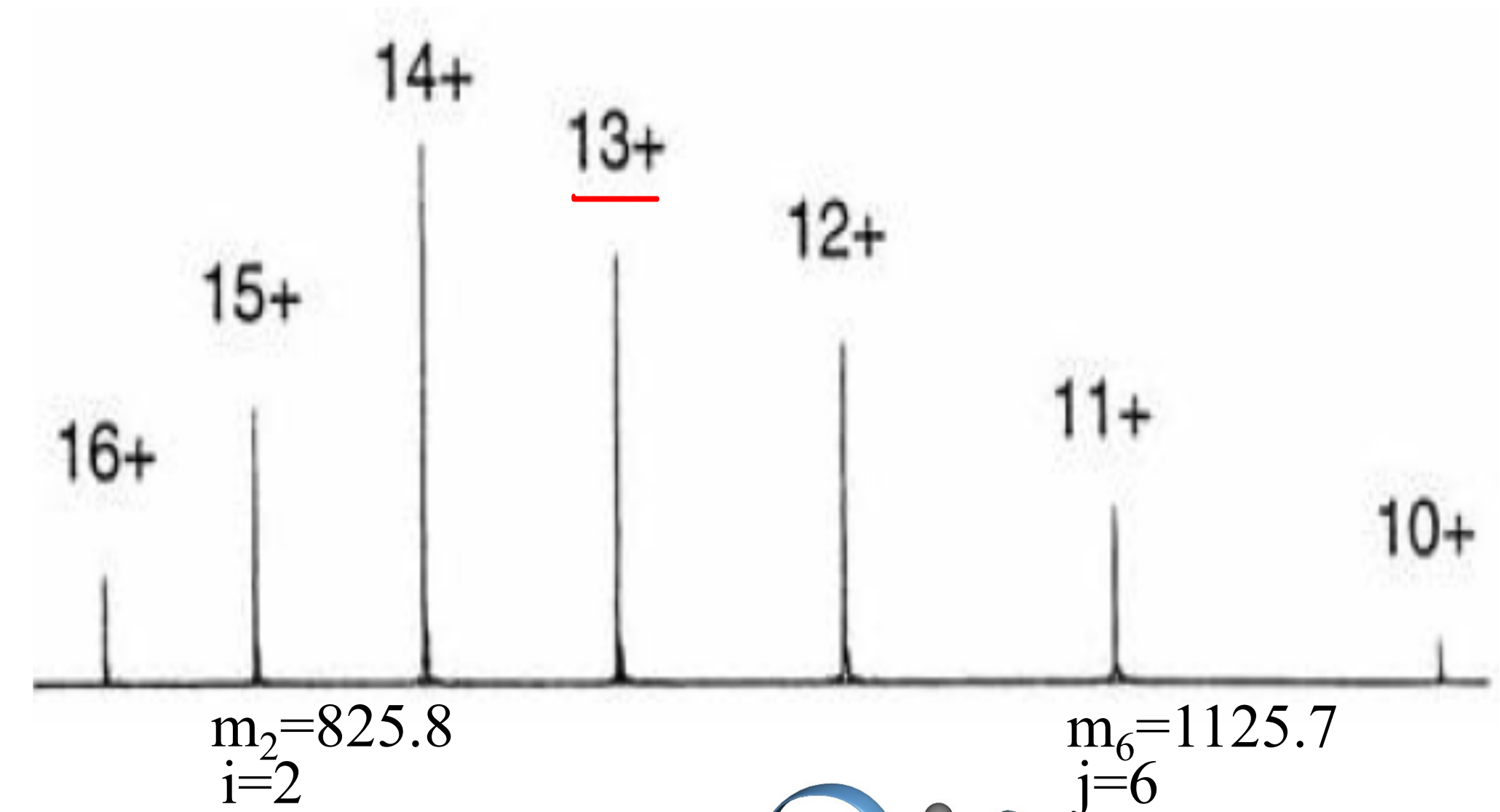

Cytochrome-c,  
“recycling” protein

# Electrospray ionization

## Advantages

- Soft ionization
- Directly from solution
- Coupling with online separation (i.e., HPLC)
- High accuracy for large molecules
- Large mass range
- Fast
- Preserves non-covalent interactions

## Disadvantages

- Complicated spectra
- Less tolerant to salts
- Relatively low ionization efficiency



# DESI Mechanism

- DESI occurs when analyte particles are solvated by an ionized solvent flow.
  - The solvated analyte is ejected from the sample and swept toward the mass analyzer.
  - The mechanism and spectra are very similar to ESI.

# DESI Applications

DESI can be used in a wide variety of applications

1. Pharmaceutical testing
  - Quality control/assurance
  - Counterfeit identification
2. Chemical weapons
3. Explosive residues
4. Latent fingerprints

# Properties of MALDI matrices

## The ideal matrix should have the following properties:

- Strong absorption at the laser wavelength (chromophore)
- Solvent compatible with sample
- Homogeneous solid-state mixing with the analyte (co-crystallization)
- **Proton donor  $M \rightarrow [M+H]^+$** 
  - Ability to undergo photochemical reaction leading to proton transfer to the analyte
- **Proton acceptor  $M \rightarrow [M-H]^-$** 
  - Ability to undergo photochemical reaction leading to proton transfer from the analyte

*Different from ESI: MALDI produces only low-charged ions!*

# MALDI of Biomolecules

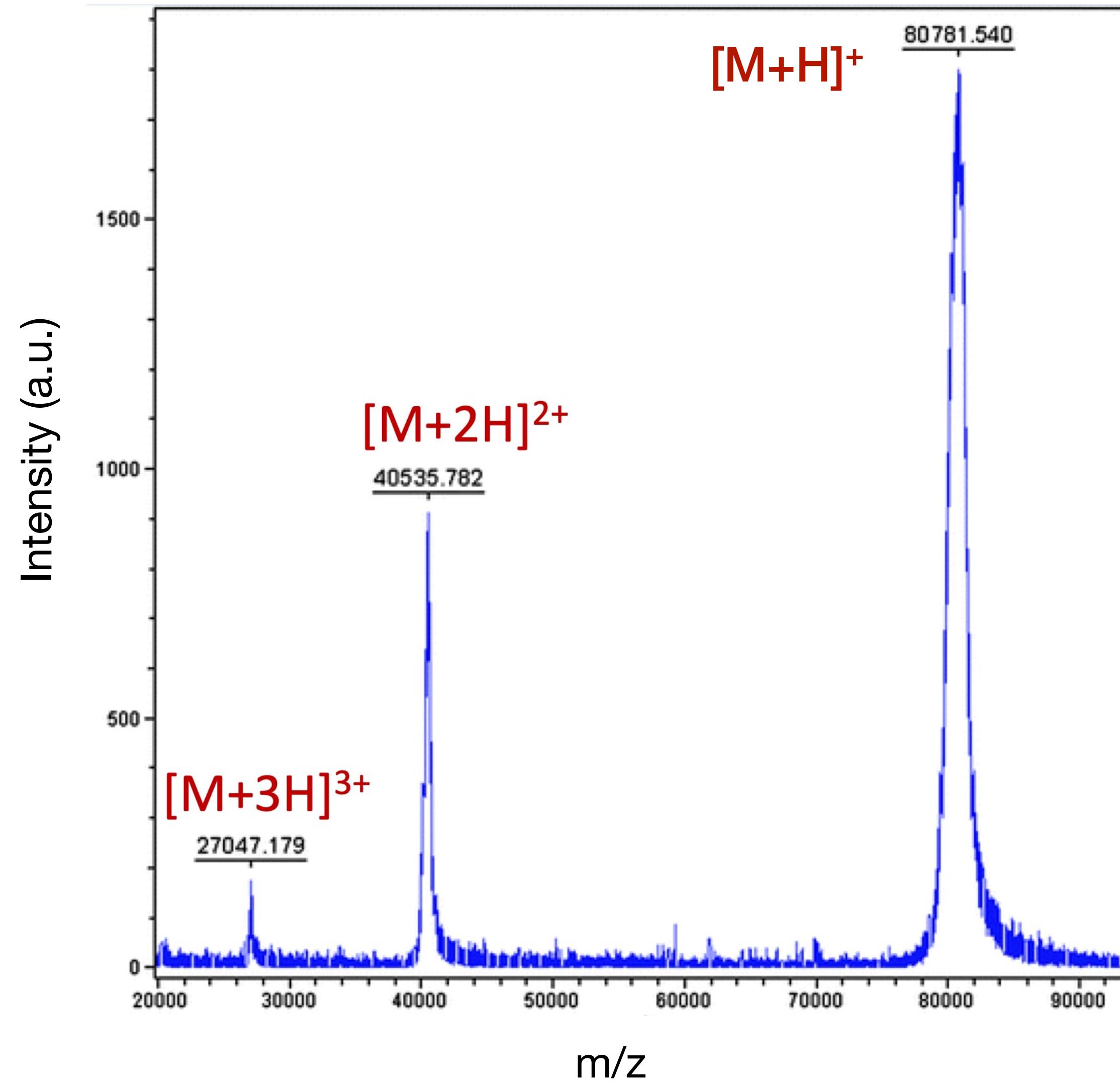

## Transferrin

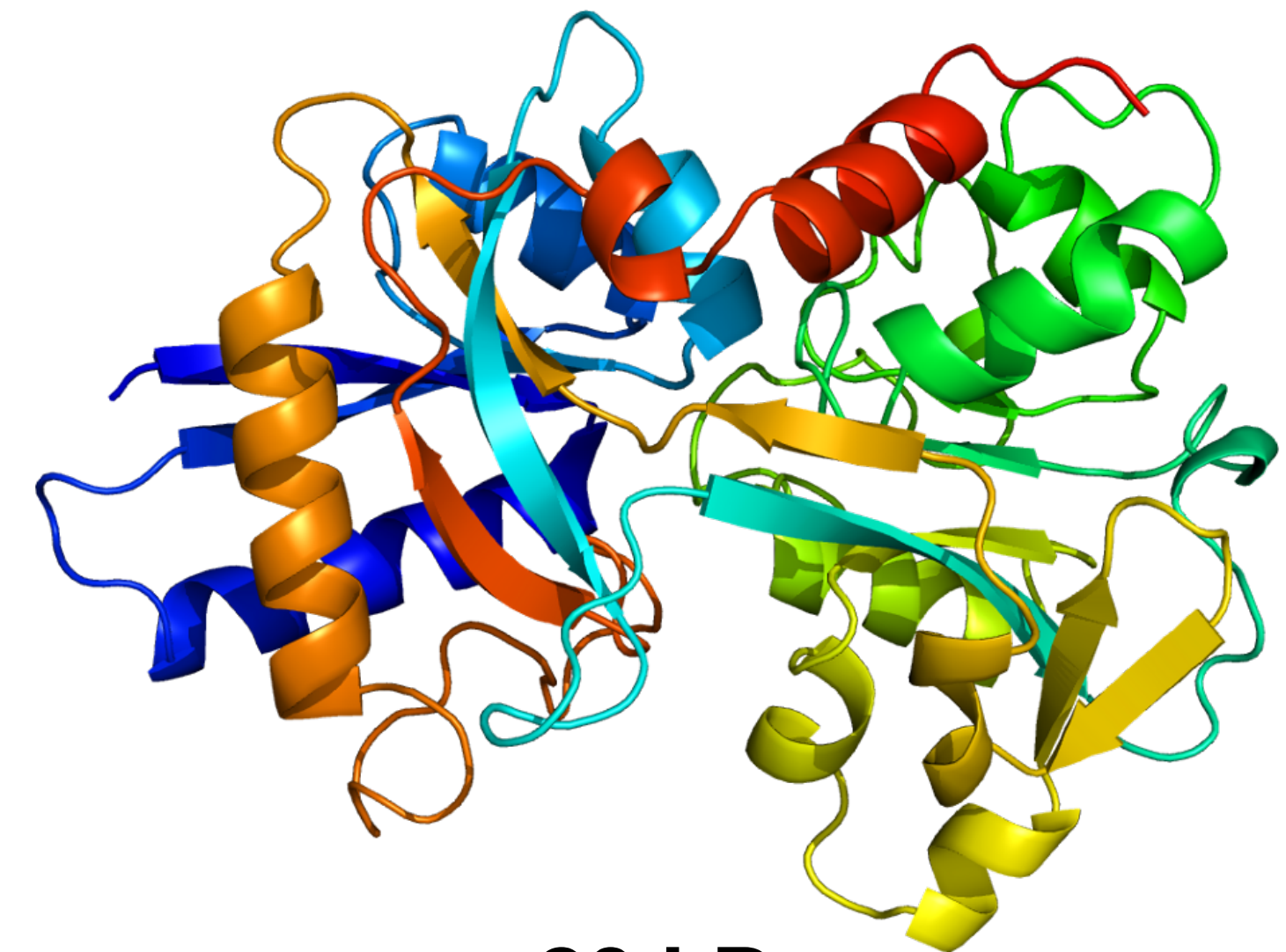

~80 kDa

Protein is co-crystallized with SA matrix

Proteins up to 200 kDa can be measured

# Matrix-assisted Laser Desorption Ionization (MALDI)

## Advantages

- Preferable for large molecules
- Very fast
- Sensitive to small amounts of sample
- Simple spectra
- Accurate
- Not affected by salts
- Soft ionization

## Disadvantages

- Needs preparation of crystals, adjusting intensity of laser, finding crystals on plate with sample
- Low shot to shot reproducibility
- Short sample life
- Singly charged ions

# The Inductively Coupled Plasma

- A plasma is a hot, partially ionized gas.
- The ICP is an argon-based, radio frequency plasma.
- The input rf frequency is either 27 or 40 MHz at powers from 1 to 2 kW.
- The plasma is formed and contained in a three tube quartz torch.
- The temperature in the central analyte channel ranges from about 6000 to 8000° K.
- At these temperatures most elements are largely atomized and ionized

# Inductively Coupled Plasma (ICP)

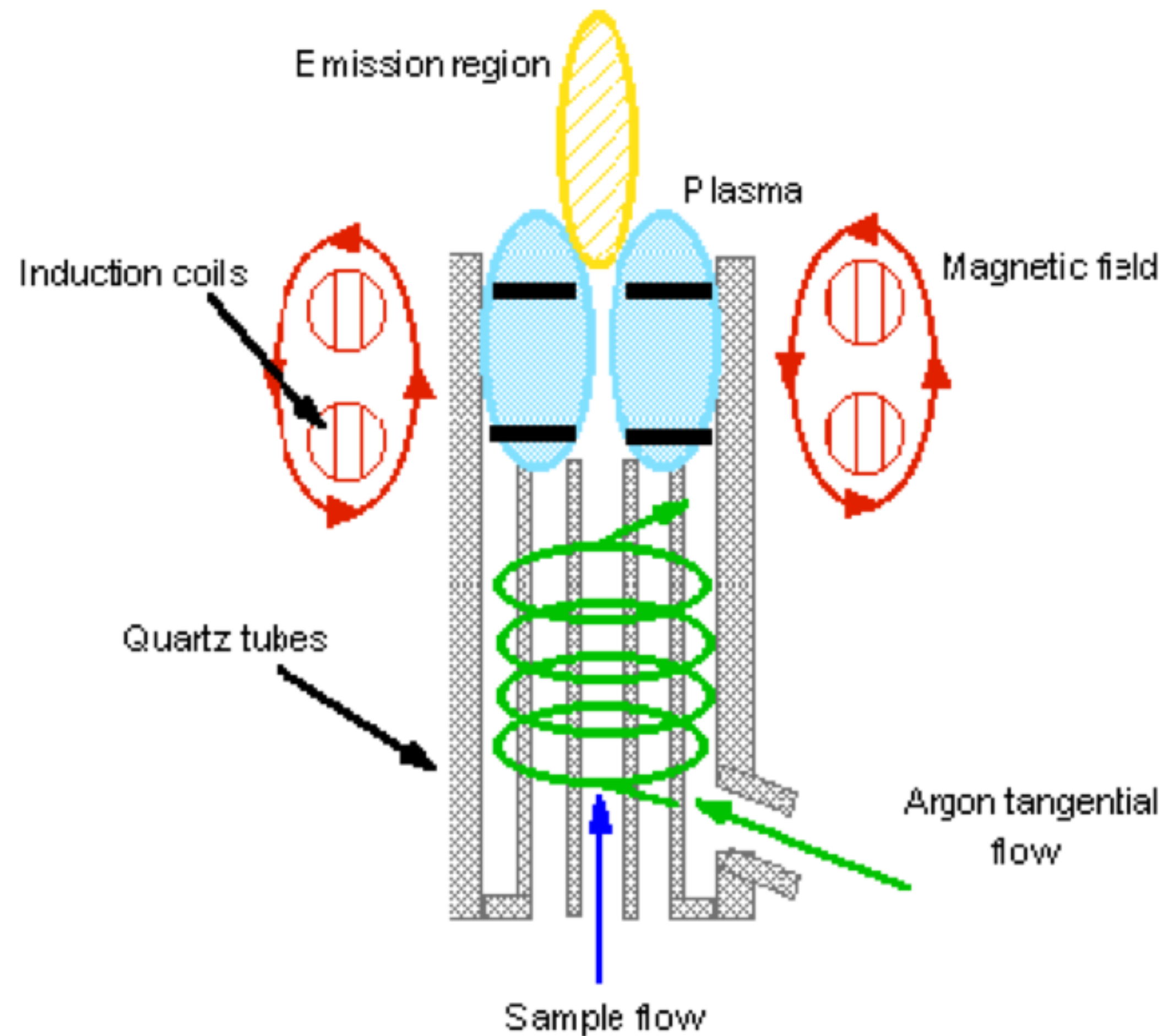

1. Ionization of Ar in a radio frequency plasma.
2. Atomization of sample due to high temperature and ionization by the plasma.

The temperature in the central analyte channel ranges from about 6000 to 8000° K

# Inductively Coupled Plasma MS

## Advantages

- Multi-element analysis
- High sensitivity
- Nearly complete isotope coverage
- Liquid, solid or gas samples
- Short analysis times
- Less “art”

## Disadvantages

- Isobaric interferences
- Relatively noisy
- Wide ion energy spread
- Inefficient
- Spectral complexity

# Mass Analyzers

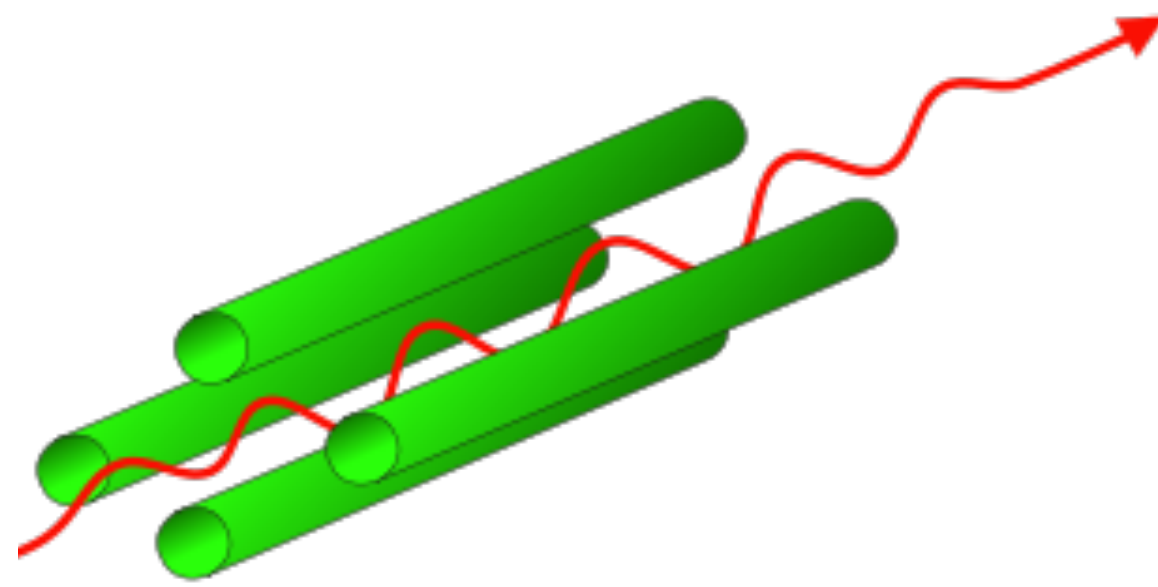

Quadrupole (Q)

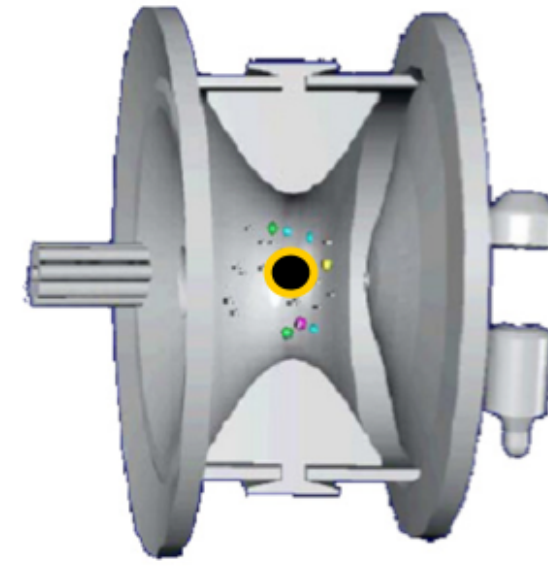

Quadrupole ion trap (QIT)

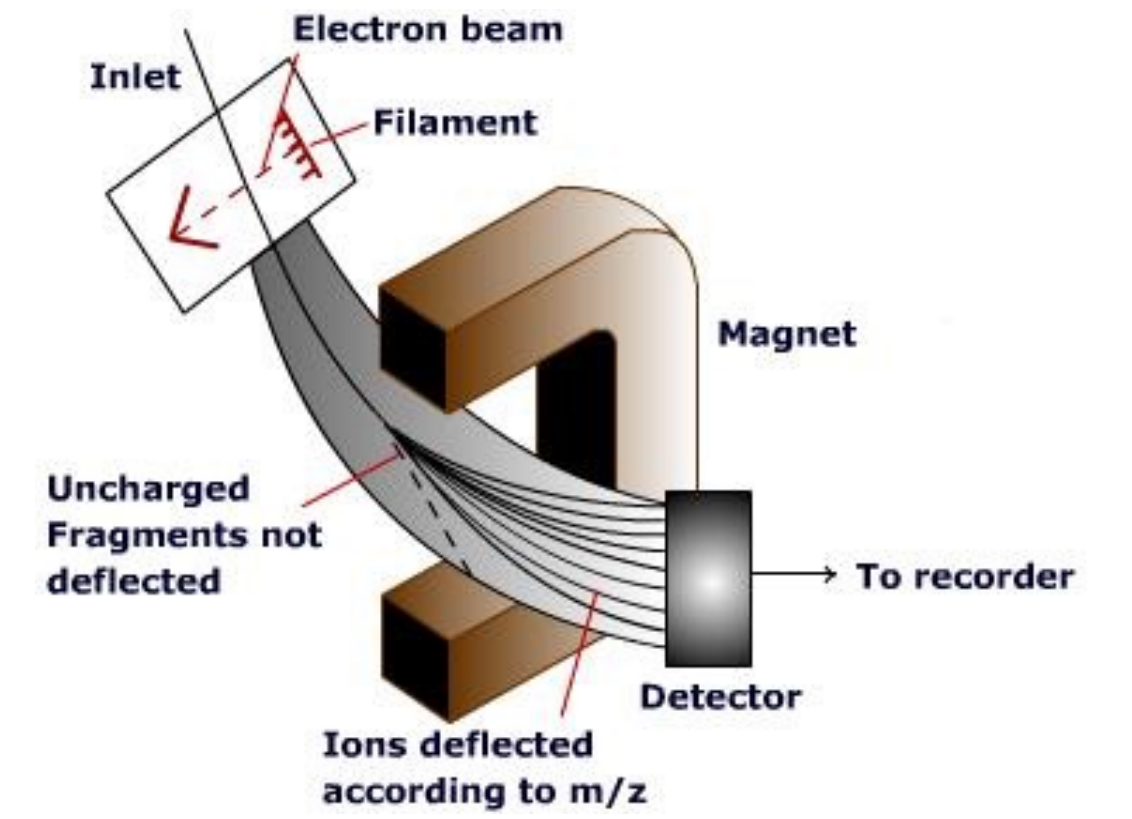

Magnetic sector

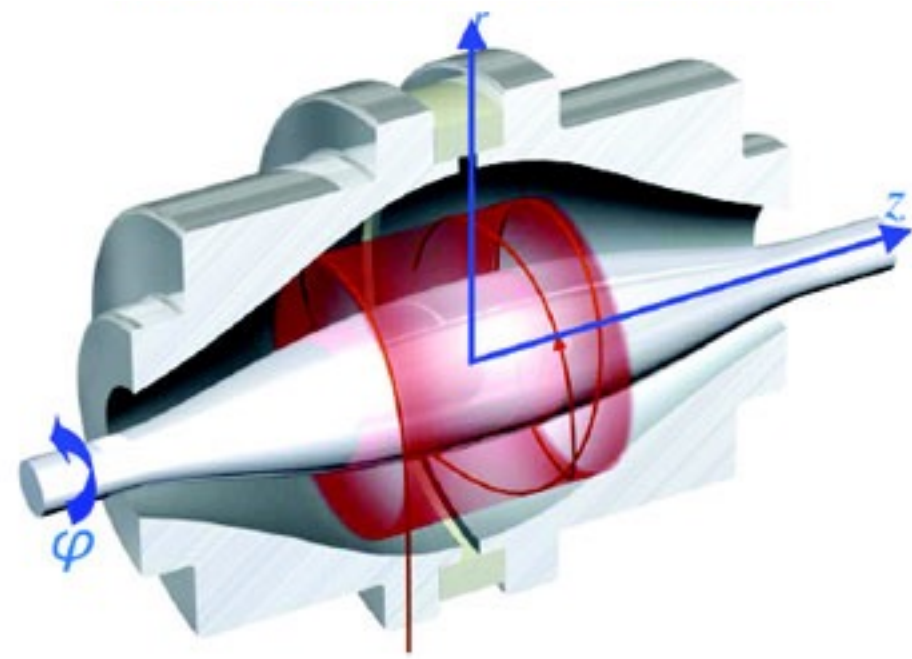

Orbitrap

Time-of-Flight (TOF)

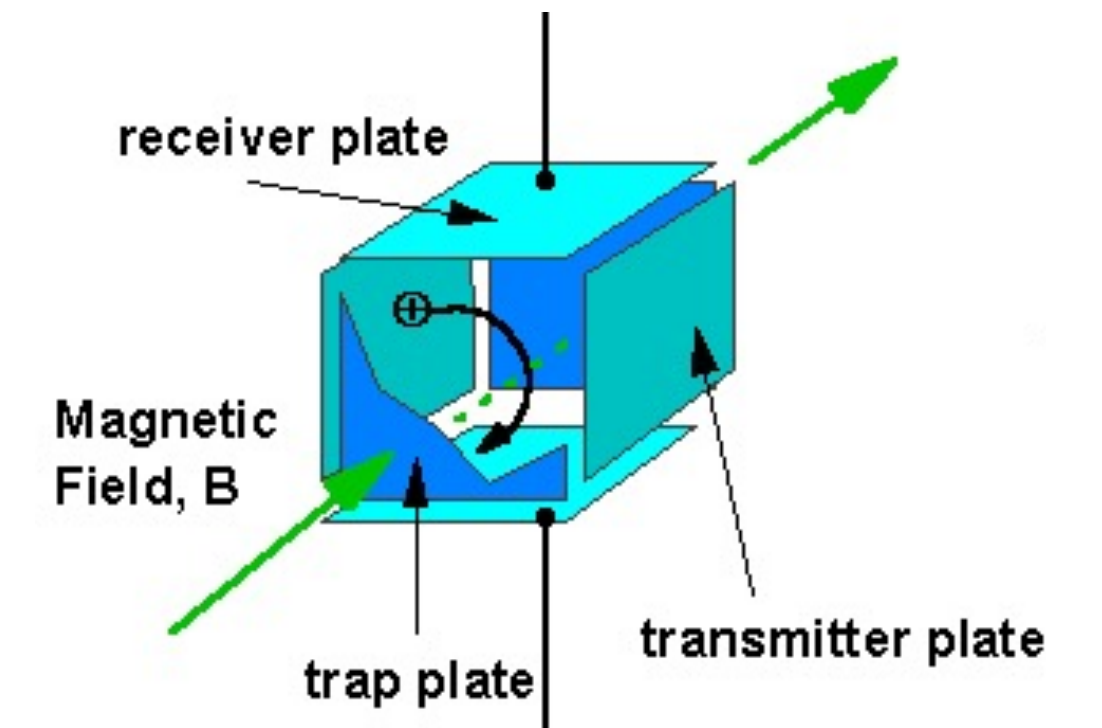
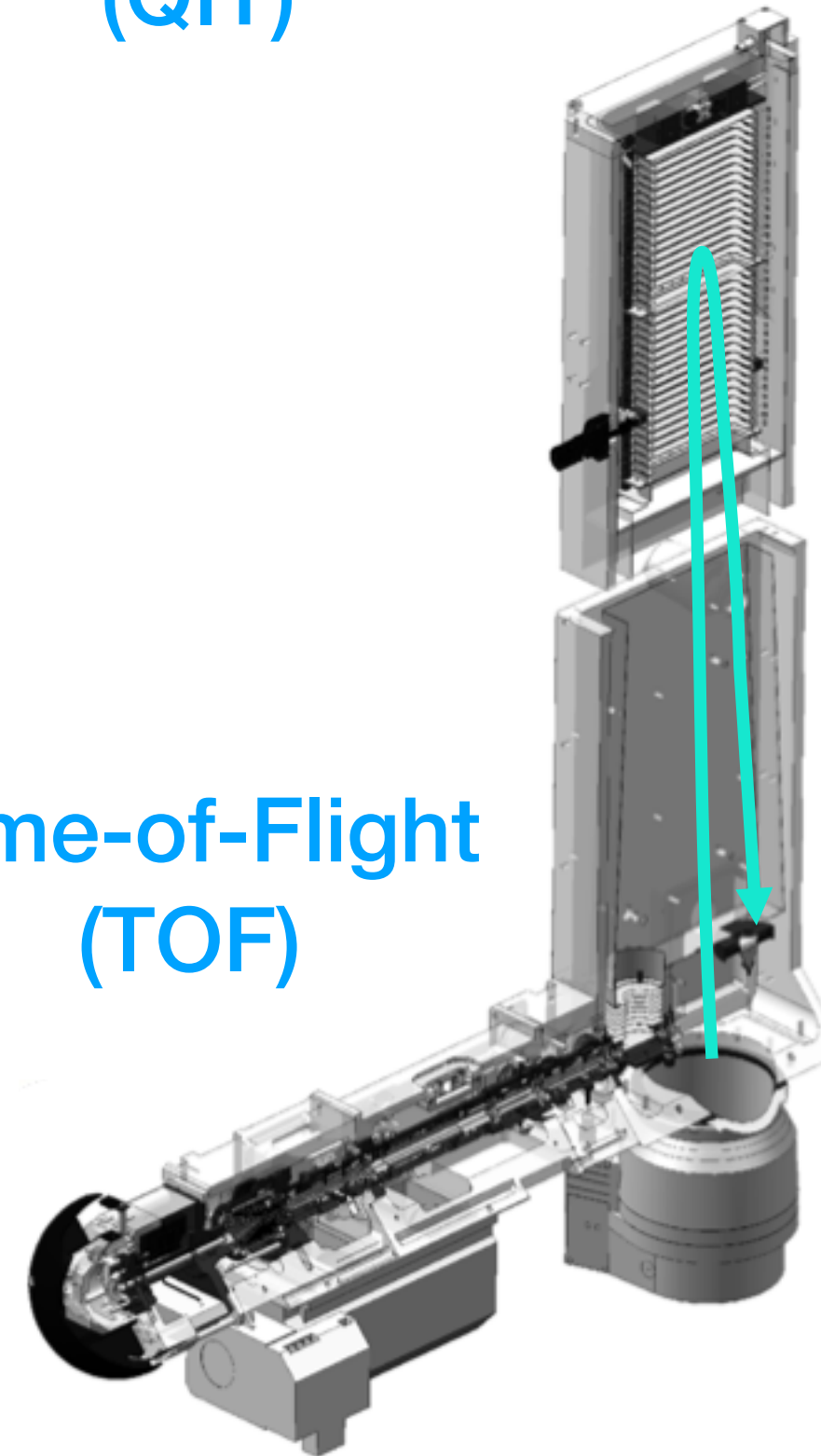

Ion cyclotron resonance (ICR)

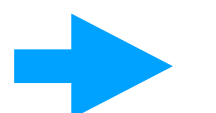

# Classification of mass analyzers

## 1. Field-free based analyzers

$$\vec{F} = m \frac{d\vec{v}(\vec{r}, t)}{dt} = 0 \quad \vec{E}(\vec{r}, t) = 0 \quad \vec{B}(\vec{r}) = 0$$

Give the ions an initial amount of energy, but then let them drift through a field-free region.

➔ **Time-of-Flight (TOF) MS**

## 2. Electric field based analyzers

$$\vec{F} = m \frac{d\vec{v}(\vec{r}, t)}{dt} = q \vec{E}(\vec{r}, t) \quad \vec{B}(\vec{r}) = 0$$

➔ **Quadrupole  
Orbitrap**

## 3. Magnetic field based analyzers

$$\vec{F} = m \frac{d\vec{v}(\vec{r}, t)}{dt} = q [\vec{v}(\vec{r}, t) \times \vec{B}(\vec{r})] \quad \vec{E}(\vec{r}, t) = 0$$

➔ **Ion cyclotron resonance (ICR)**

# Comparison of mass analyzers

Type	Resolving Power (RP)	Mass Accuracy (ppm)	Ion sampling	Scan Rate	Cost
Quadrupole	2-5000	100	Continuous	< 1 sec	\$
Ion Trap	4000	100	Pulsed		\$
TOF	20-50,000	5	Pulsed	< 0.1 sec	\$\$
Orbitrap	240,000	< 2	Pulsed	Depends on RP	\$\$\$
ICR	500,000	< 2	Pulsed	Depends on RP	\$\$\$\$
Magnetic Sector (Double-focusing)	100,000	< 5	Continuous	~ 1 sec	\$\$\$\$

# Time-of-Flight Mass Spectrometer

$$KE = q_j U_0 = \frac{1}{2} m_j v_j^2$$

$$\rightarrow v_j = \sqrt{\frac{2q_j U_0}{m_j}}$$

For  $d \ll L$ :

$$\tau_j = \frac{L}{v_j} = L \sqrt{\frac{m_j}{2q_j U_0}}$$

$$\left(\frac{m}{q}\right)_j = \frac{2U_0}{L^2} \tau_j^2$$

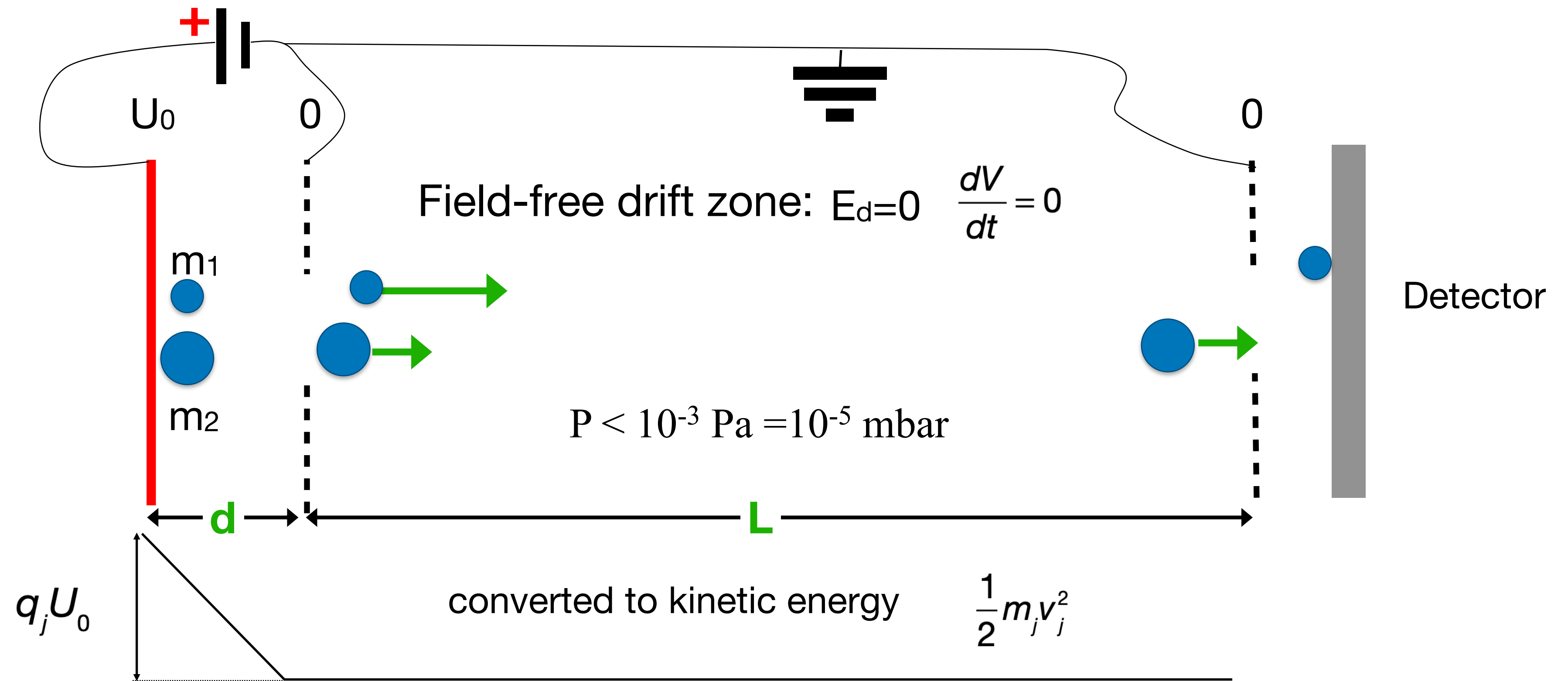

Ions with larger  $m/z$  arrive to detector later

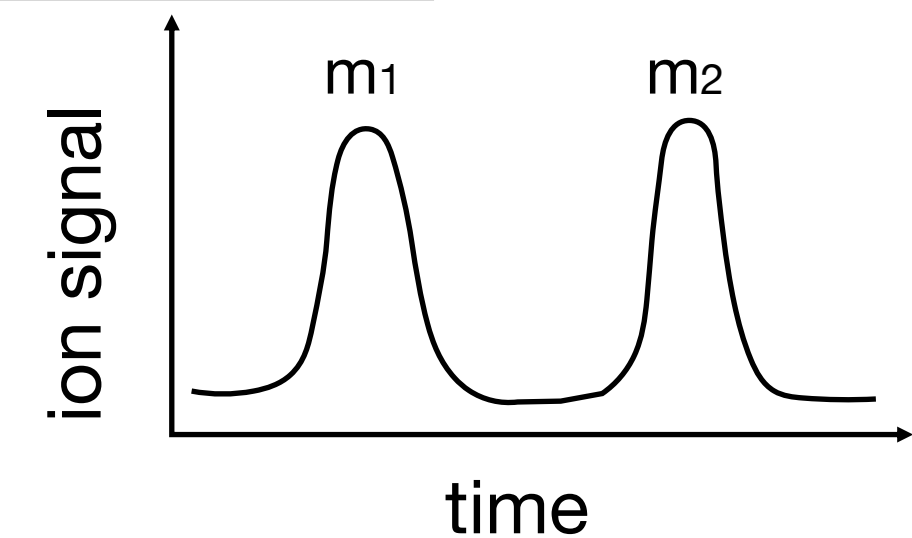

Need low pressure:  $P[mBar] = \frac{0.066}{L[mm]} \ll \frac{0.07}{10^3} \approx 7 \cdot 10^{-4} mBar;$

# Time-of-Flight Mass Spectrometer

Accounting for  $d$   $\tau_j = \tau_{0j} + \tau_{1j} = (L + 2d) \sqrt{\frac{M_j}{2q_j U_0}} = \left(1 + \frac{2d}{L}\right) \tau_{0j}; \quad \left(\frac{m}{q}\right)_j = \frac{2U_0}{L^2} \tau_j^2$

Resolution of *TOF MS*:

*Resolution is primarily limited by spatial and thermal distribution of ions in the accelerating region*

$$\Delta m \simeq dm = \frac{2 \cdot U}{L^2} d(\tau^2) = \frac{4U}{L^2} \tau \cdot d\tau; \quad d\tau_{d,U} = d[L + 2d] \sqrt{\frac{m}{2q \cdot U}} \approx L \sqrt{\frac{m}{2q}} \cdot d(U^{-1/2}) + 2 \sqrt{\frac{m}{2q \cdot U}} d(d)$$

$$d\tau_{d,U} = -L \sqrt{\frac{m}{2q}} \cdot \frac{dU}{2U^{3/2}} + 2 \sqrt{\frac{m}{2q \cdot U}} d(d) = \sqrt{\frac{m}{2q \cdot U}} \left(2d(d) - \frac{L \cdot dU}{2U}\right);$$

$$R = \frac{m}{\Delta m} \simeq \frac{L \sqrt{\frac{m}{2q \cdot U}}}{\sqrt{\frac{m}{2q \cdot U}} \cdot \left(2\Delta d - \frac{L \cdot \Delta U}{2U}\right)} = \frac{1}{\left(\frac{2 \cdot \Delta d}{L} - \frac{\Delta U}{2U}\right)}$$

**Resolution of a TOF MS does NOT depend on mass  $m$**

# TOF: Reflectron

$$mgH = \frac{mV^2}{2}$$

(a)

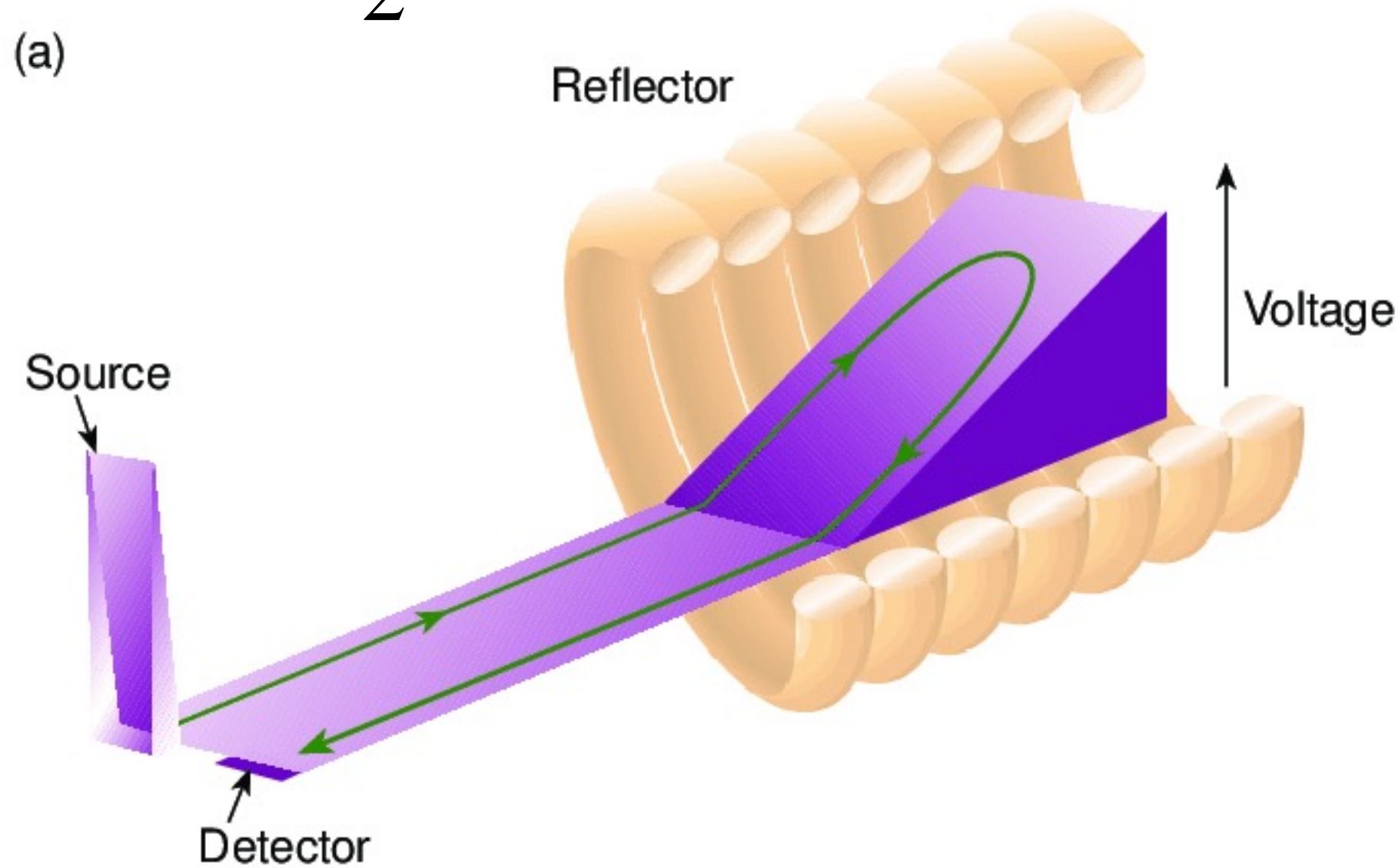

- Series of spaced metallic electrodes onto which a positive gradient of potential is applied
- The resulting electric field slows down the ions entering in the mirror: ions stop, reverse course and are reaccelerated
- Higher energy ion penetrates further into the field before reversing, yielding longer flight path

(b)

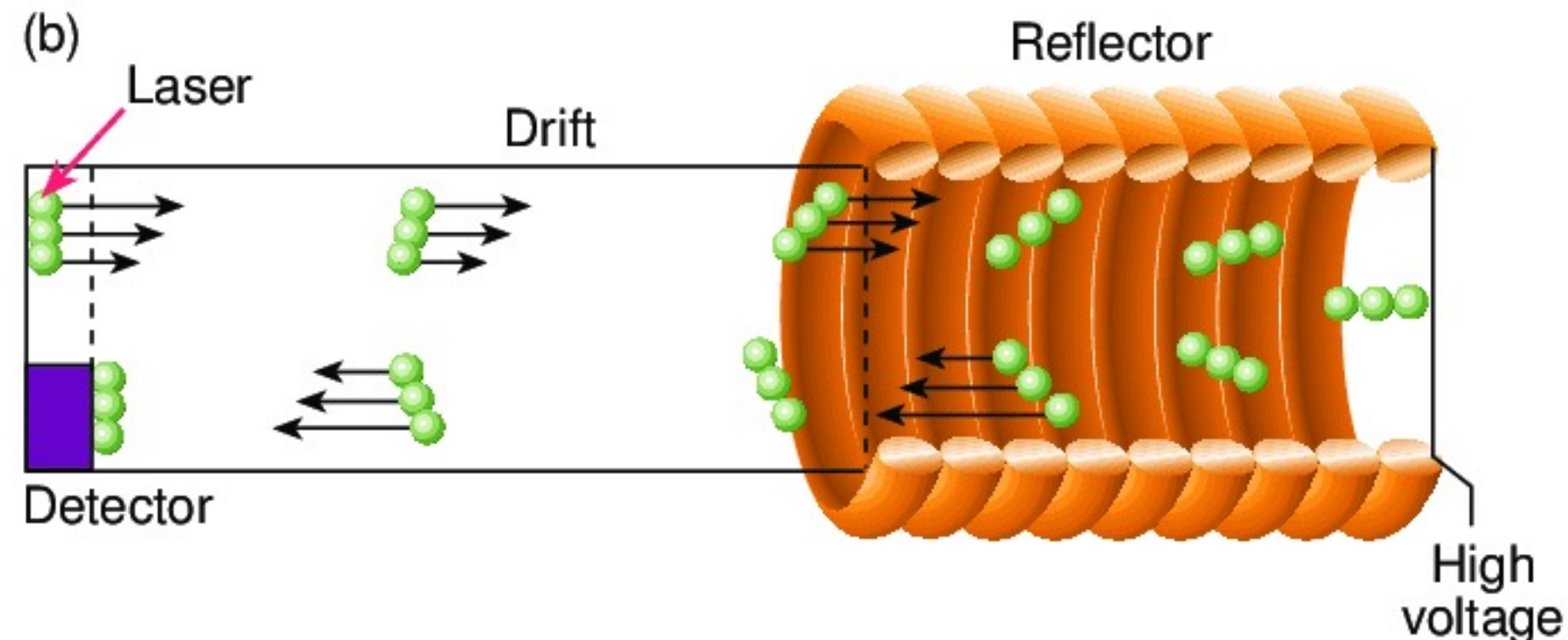

- The detector is positioned off-axis



**Ions of same  $m/z$  arrive at detector at the same time**

# Time-of-Flight Mass Spectrometer (TOF MS)

## Advantages

- Good mass accuracy: 5-10 ppm
- High mass resolution: Up to 40'000
- High mass range:  $> 10^5$  Da
- Acceptable linearity
- Very good reproducibility
- Very fast acquisition time

# Quadrupole mass spectrometer

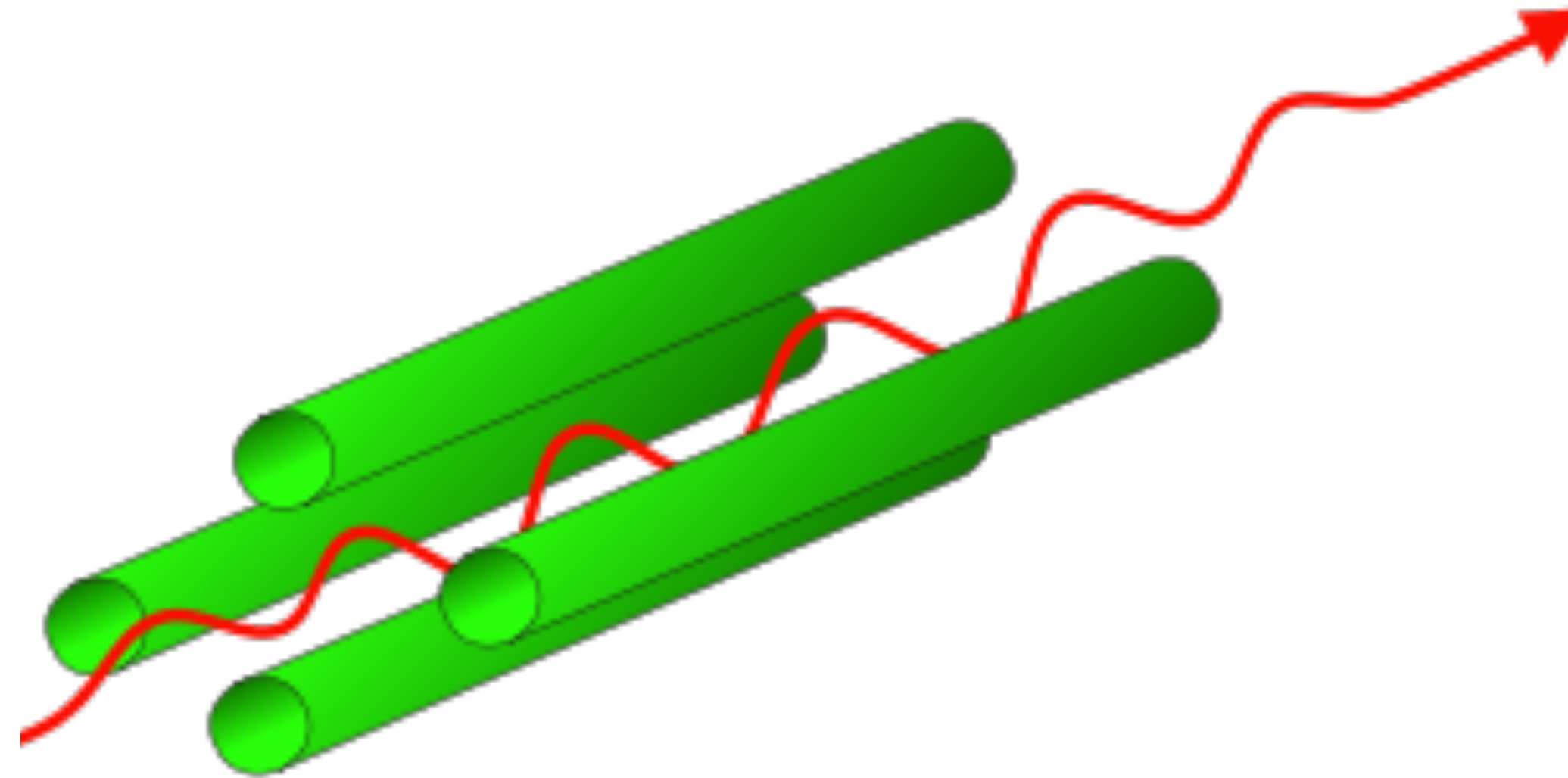

- Quadrupole is a  $m/z$  filter;
- Quad contains 2 pairs of cylindrical metal rods: opposite rods are electrically connected together.

# Linear quadrupole mass analyzer

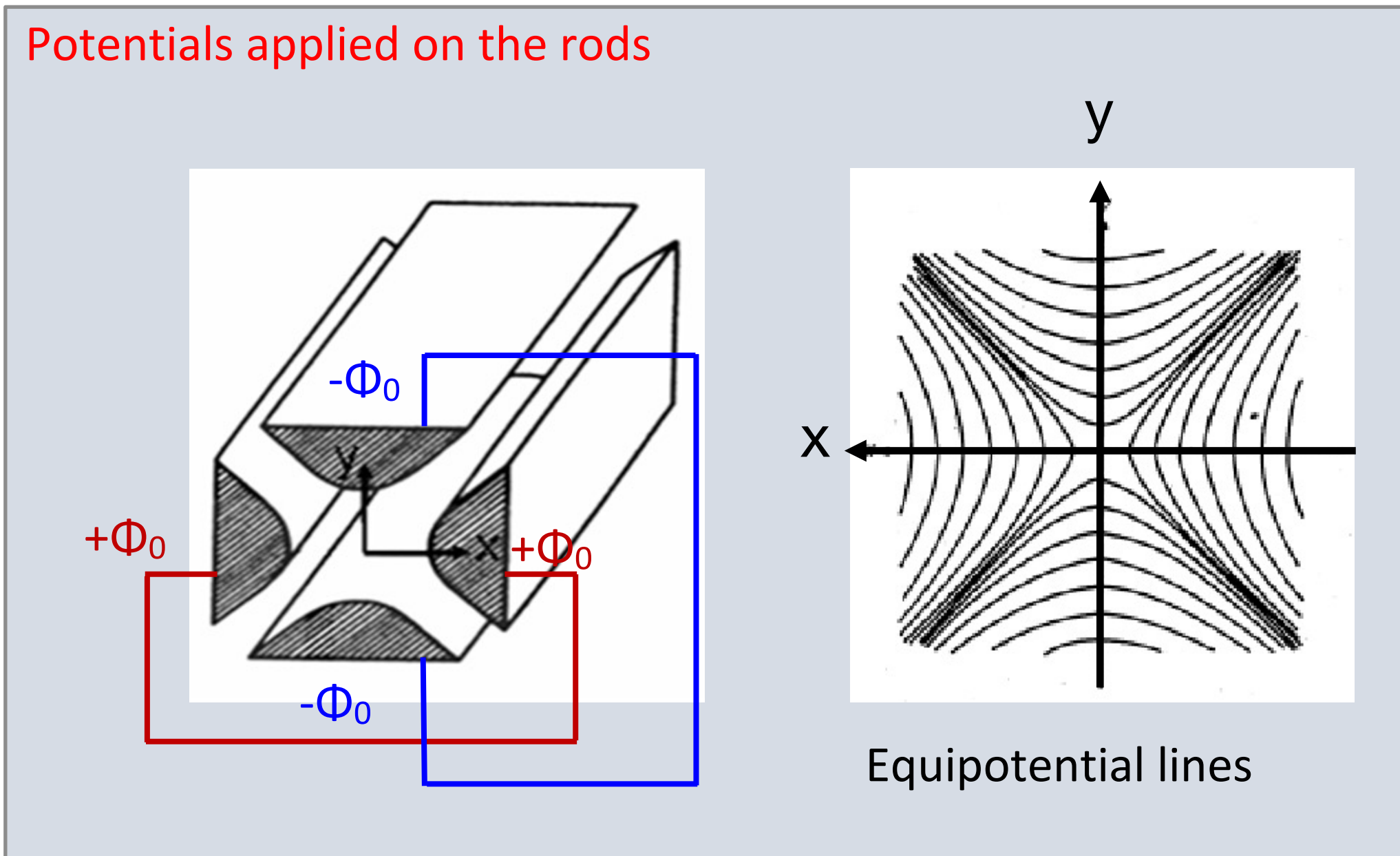

U: Direct potential (DC)

V: RF amplitude (AC)

Typically

U: 500-2000V

V: 0-3000 V

$\omega=2\pi f$  where  $f$  is the frequency of the RF field (typically 1 MHz)

X-rods  $\Phi_0 = +(U - V \cos \omega t)$

Y-rods  $-\Phi_0 = -(U - V \cos \omega t)$

(180° out of phase)

Quadrupoles are operated at  
fixed frequency but variable U & V

Variables: **U** and **V**; Parameter: **m**

$$a_y = \frac{8zeU}{m\omega^2 r_0^2}$$

$$a \propto U/m; \quad q \propto V/m$$

$$q_y = \frac{4zeV}{m\omega^2 r_0^2}$$

$$a/q = 2U/V$$

$$\mathbf{P}(a, q) = \mathbf{0.237; 0.706}$$

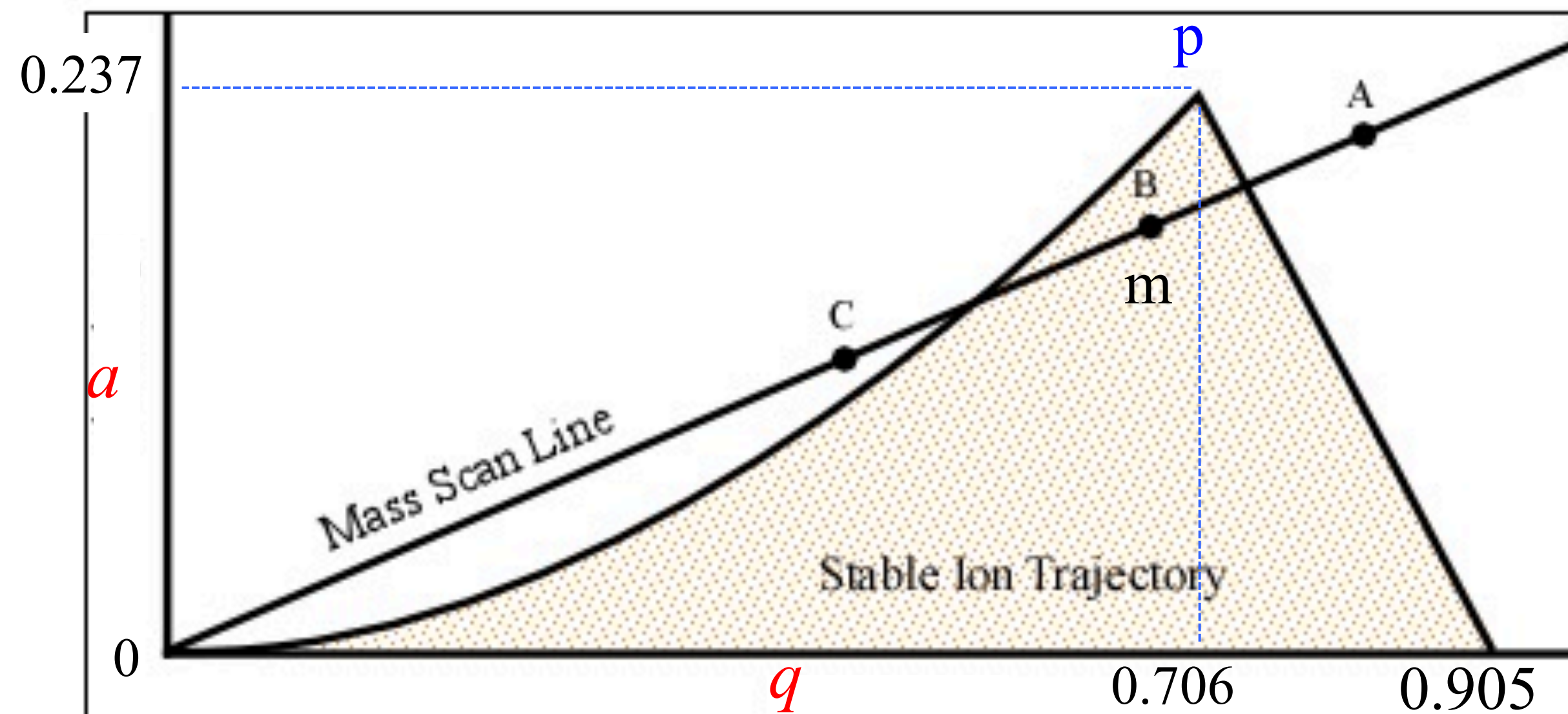
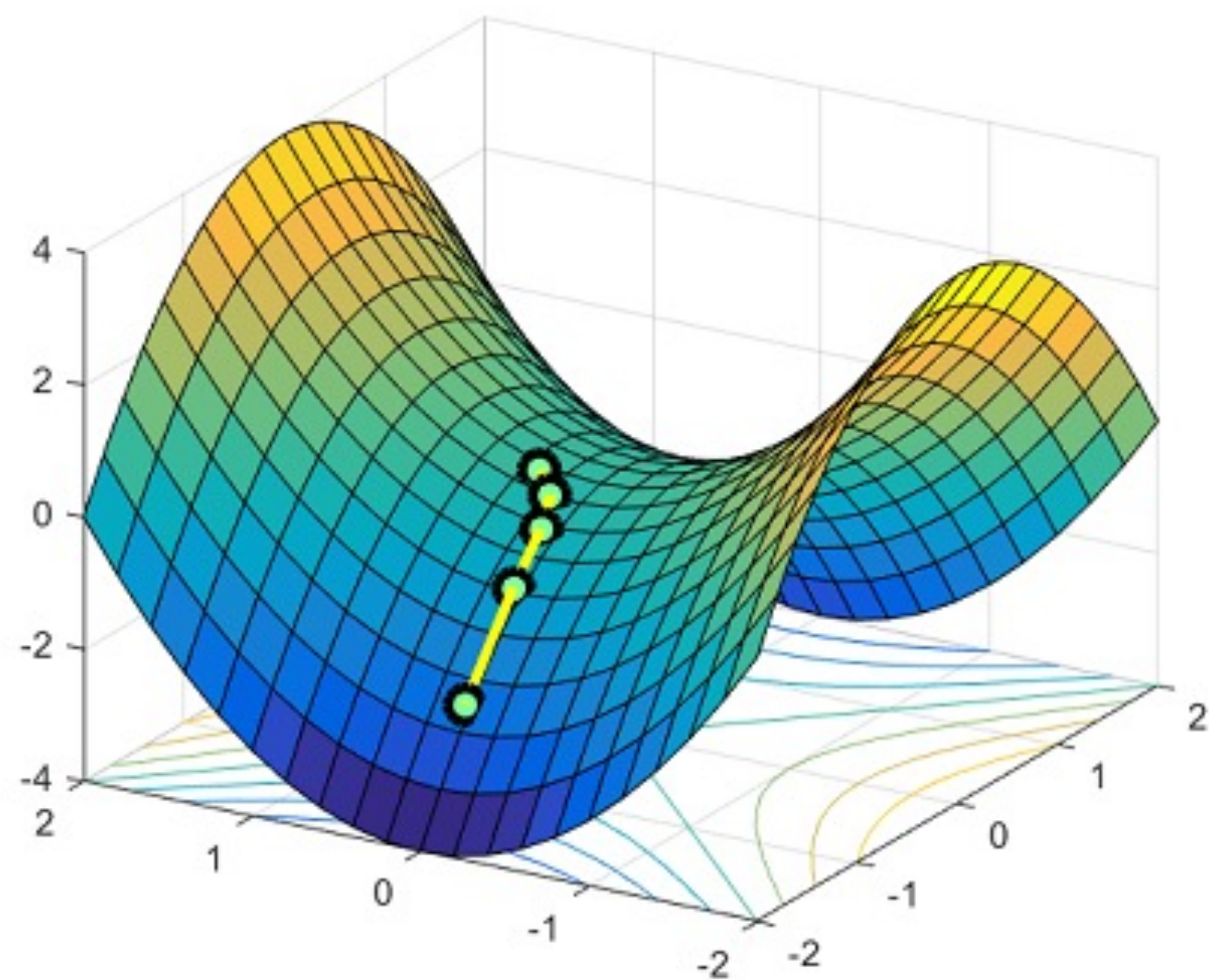

*time dependent solutions:*

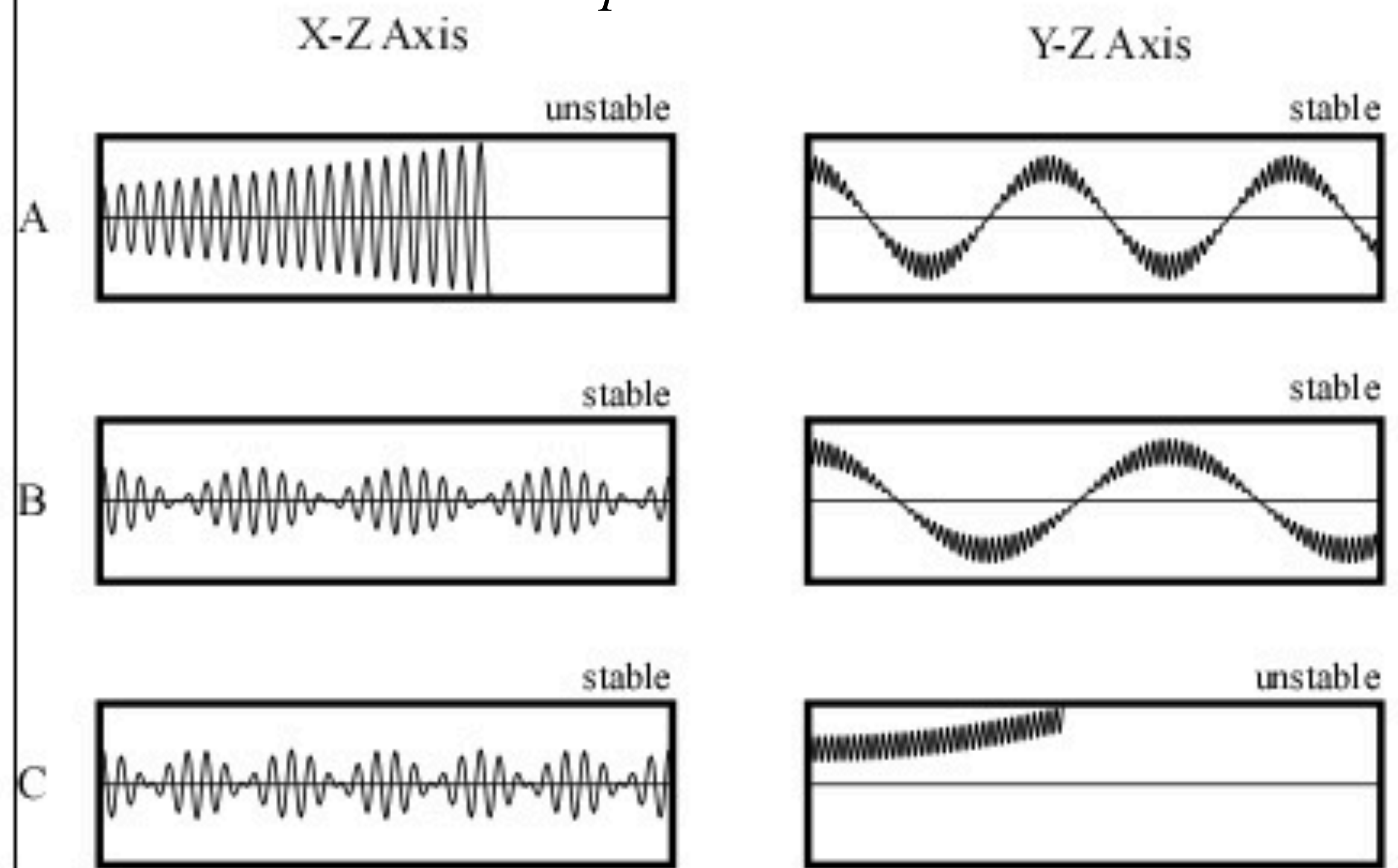

Variables: **U** and **V**; Parameter: **m**

$$a_y = \frac{8zeU}{m\omega^2 r_0^2} \quad a \propto U/m; \quad q \propto V/m$$

$$q_y = \frac{4zeV}{m\omega^2 r_0^2} \quad a/q = 2U/V$$

**P(a, q) = 0.237; 0.706**

The diagram can be easily converted to U, V coordinates

- Each **m** yields its own “*triangle of stability*” in U, V
- The smaller is **m** the smaller are **U** and **V** of the triangle peak
- Trajectories are unstable if:

$$\frac{U}{V} = \frac{a_p}{2 \cdot q_p} > 0.1678$$

For  $U=0$  ions with all masses up to max go through

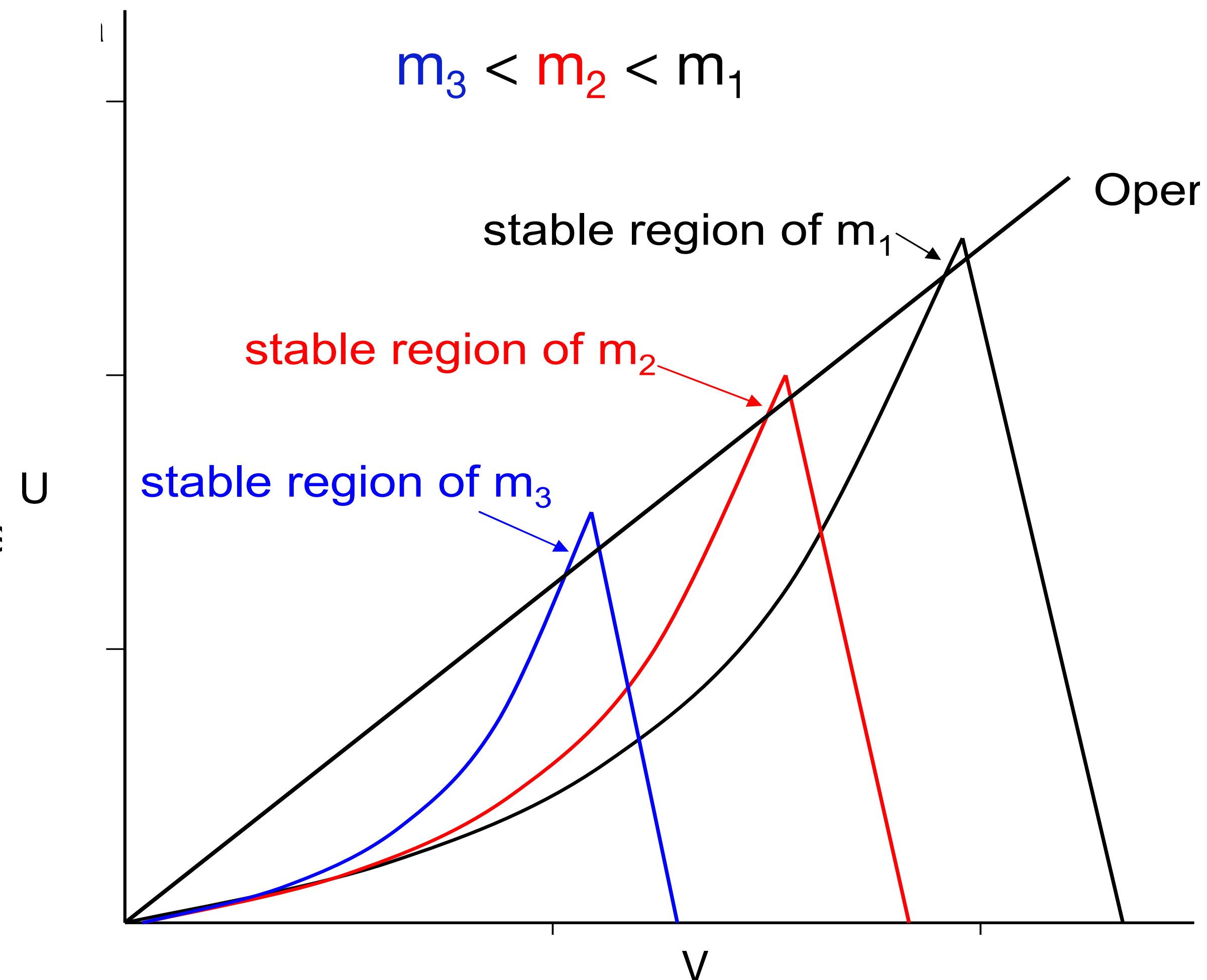

- Scan up U and V simultaneously, such that  $U/V = \text{const} < 0.1678$ ;
- Single Mass-command  $U_{MC}$  DC voltage controls U and V:



# Resolution of QMS

- MS is the number of ions that pass through in function of  $U_{MC}$ :  $U \propto V \propto U_{MC}$
- The points where the scan line crosses the triangle of a specific  $m/z$  determines the transparency window ( $\Delta U$ ,  $\Delta V$ ,  $U/V = \text{const}$ ) for this  $m/z$ .  $\Rightarrow$
- For ions with  $m_1/z$  the width of the mass peak is determined by  $\Delta U_1$ ,  $\Delta V_1$ :

$$U \propto V \propto m/z; \Rightarrow \Delta(m/z) \propto m/z \Rightarrow$$

$$FWHM \propto \Delta(m/z) \propto m/z$$

$$R = \frac{m}{FWHM} = \text{const}$$

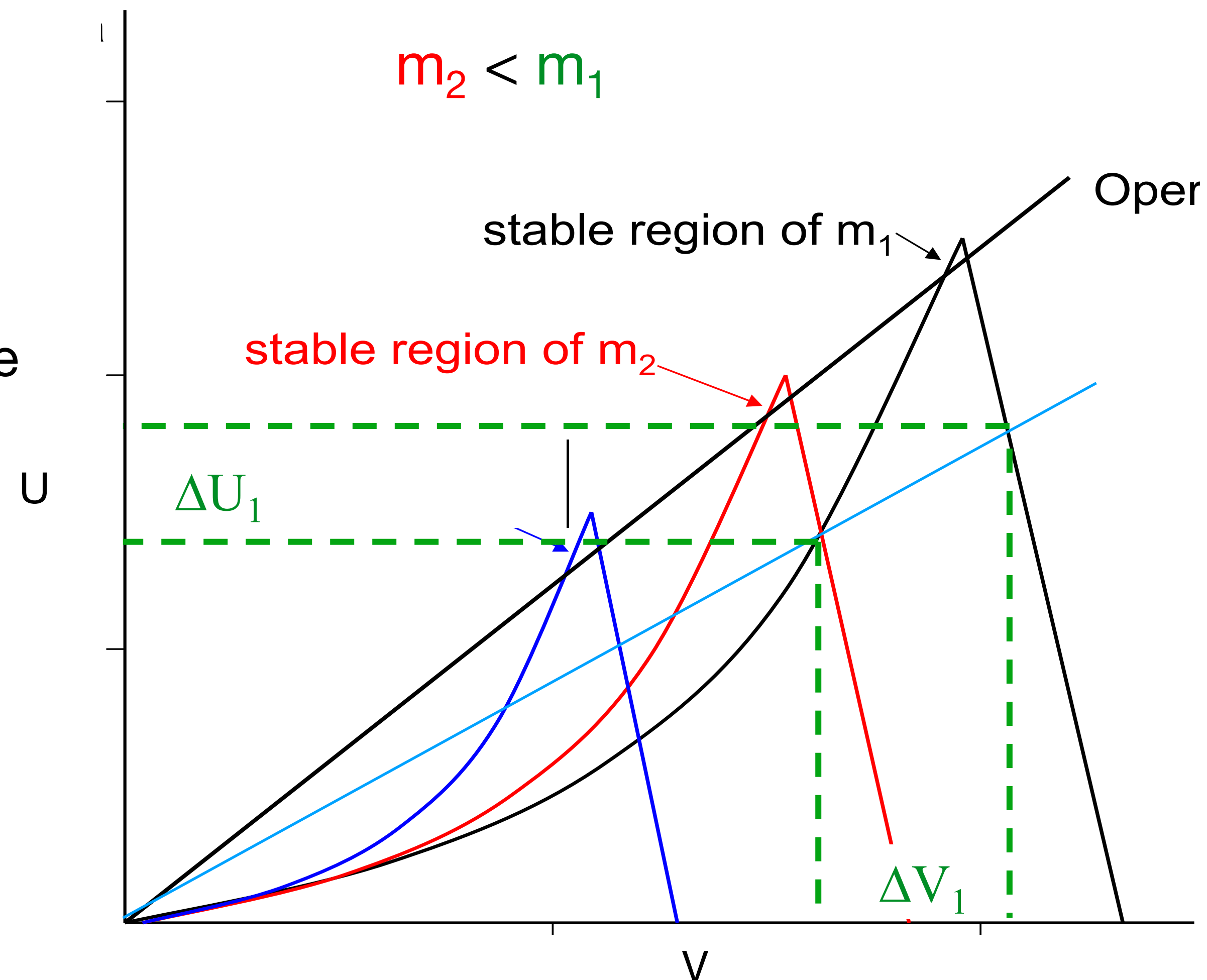

- Resolution of quadrupole MS is nearly constant across transmission range;
- Resolution increases (but transmission drops) upon approaching to the  $(U, V)$  apex point.

# Linear quadrupole MS

## **Advantages**

- Small and lightweight: ~20 cm long
- Inexpensive
- Simple to operate
- Low accelerating voltage can accommodate high source pressures

## **Disadvantages**

- Limited mass resolution and mass range
- Contamination of rods can degrade resolution and sensitivity

# Ion Cyclotron Resonance (ICR)

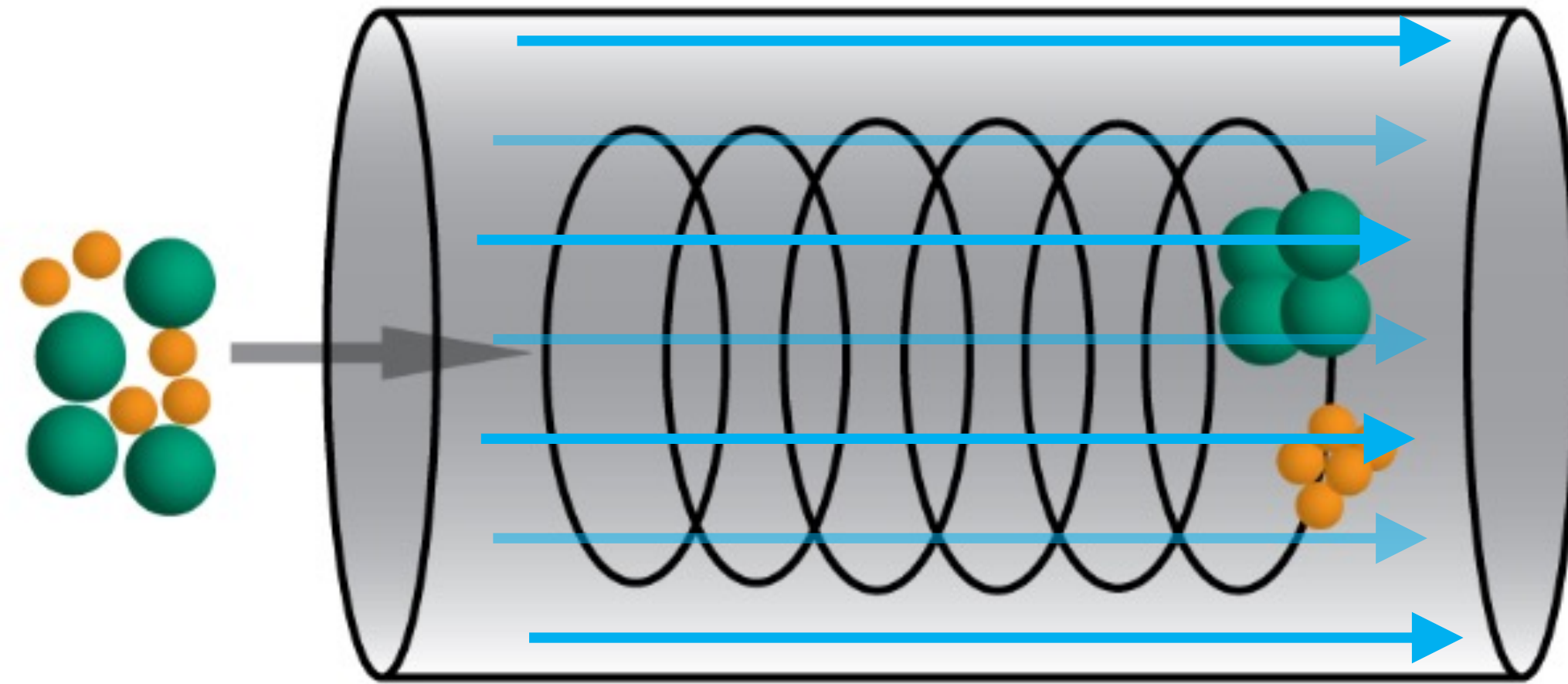

Based on interaction of charges with permanent homogeneous magnetic field

# Motion of ions in magnetic field

When the ion velocity vector is not orthogonal to magnetic field, only the velocity component contributes to cyclotron motion,  $\vec{V}_{\perp}$

$$r = \frac{m \cdot V}{e \cdot Z \cdot B} \quad \omega = \frac{eZ}{m} B$$

while the  $\vec{V}_{\parallel}$  component along the field doesn't change. The trajectory of the charge then is a helix.

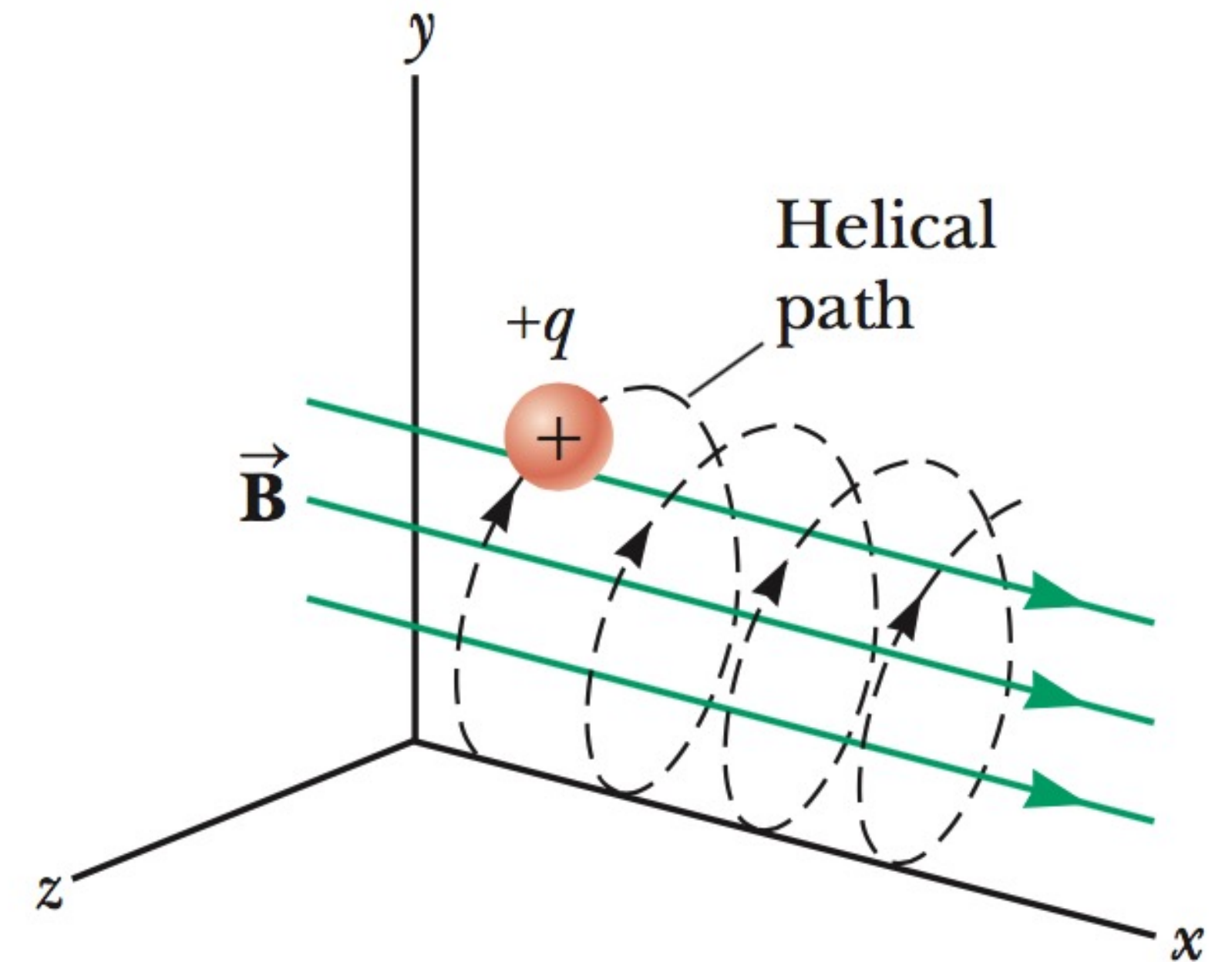

- In a fixed magnetic field  $\omega_c$  depends only on  $q/m$ ;
- This fact is used in Ion Cyclotron Resonance mass spectrometers (ICR MS) to determine  $m/Z$  of ions by measuring  $\omega_c$ .

# What Could We Do With Ions In The orbitrap?

## Image current detection

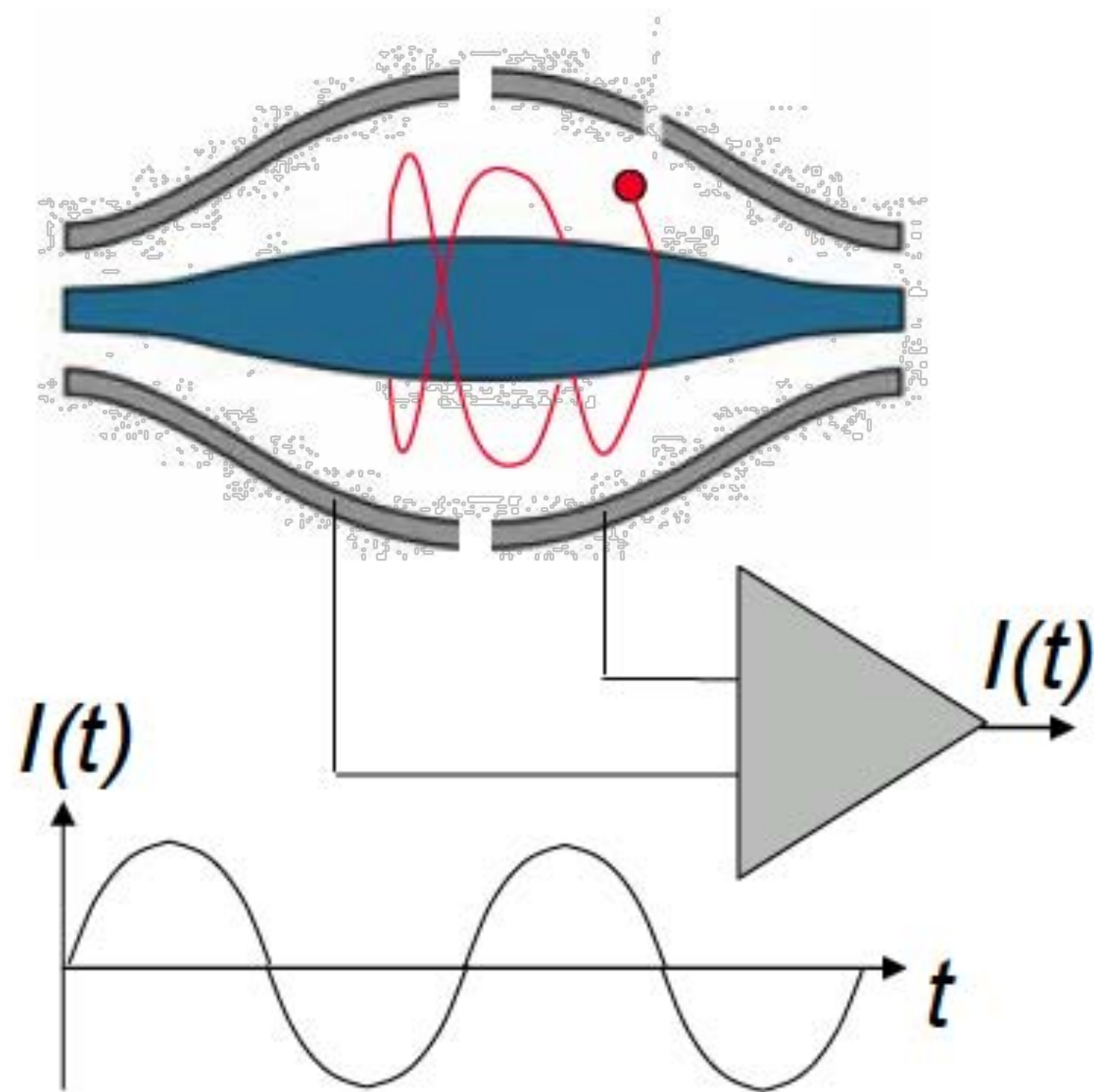

**Notes:**

- All-mass detection
- Noise equiv. to 20 ions (1 sec)



## When the size does matter !

First published theory: 1981;  
First instrument: 2006.

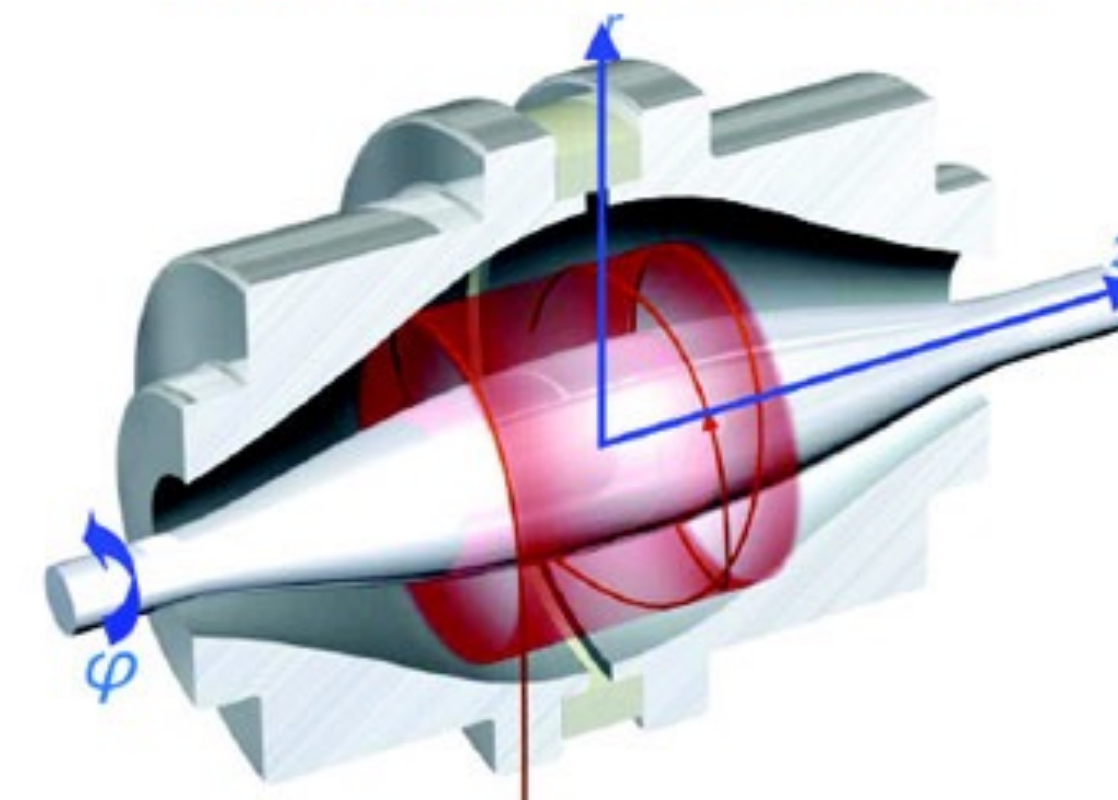

# Electrostatic field in the orbitrap

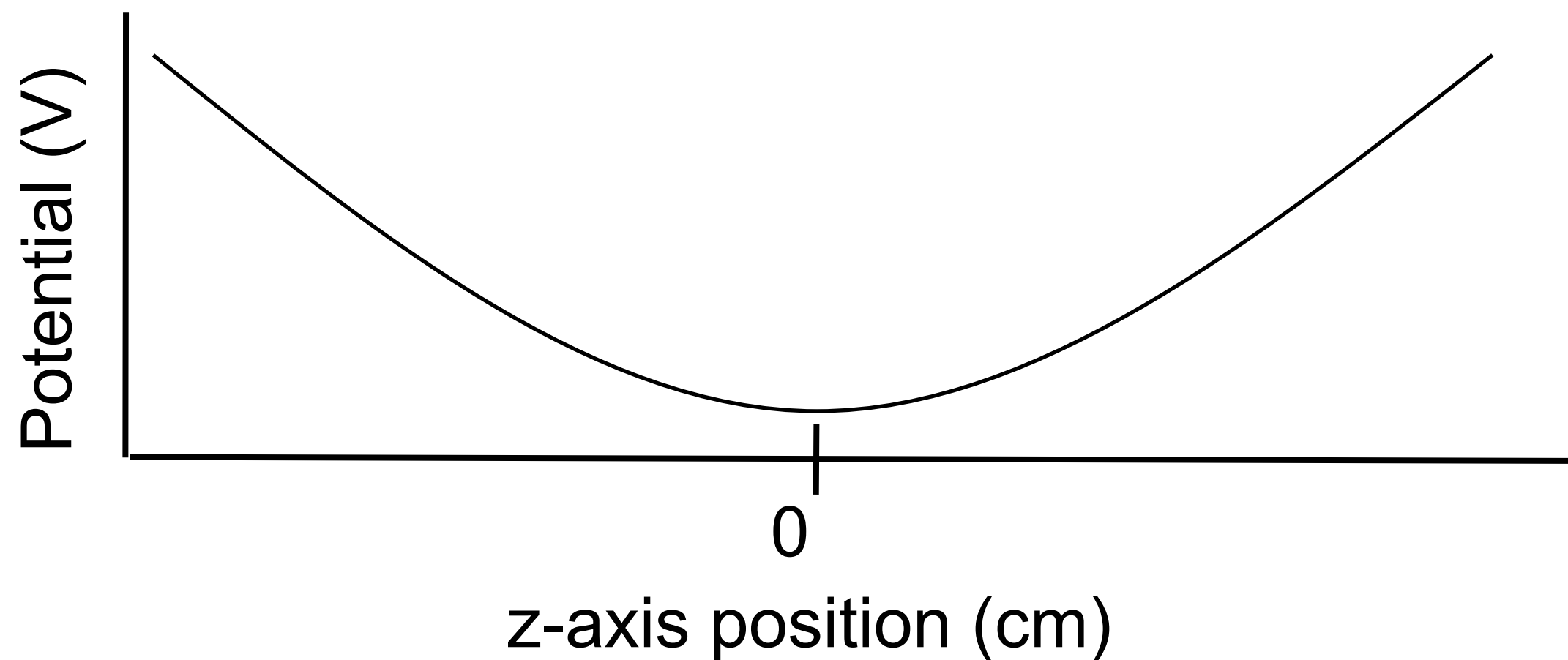
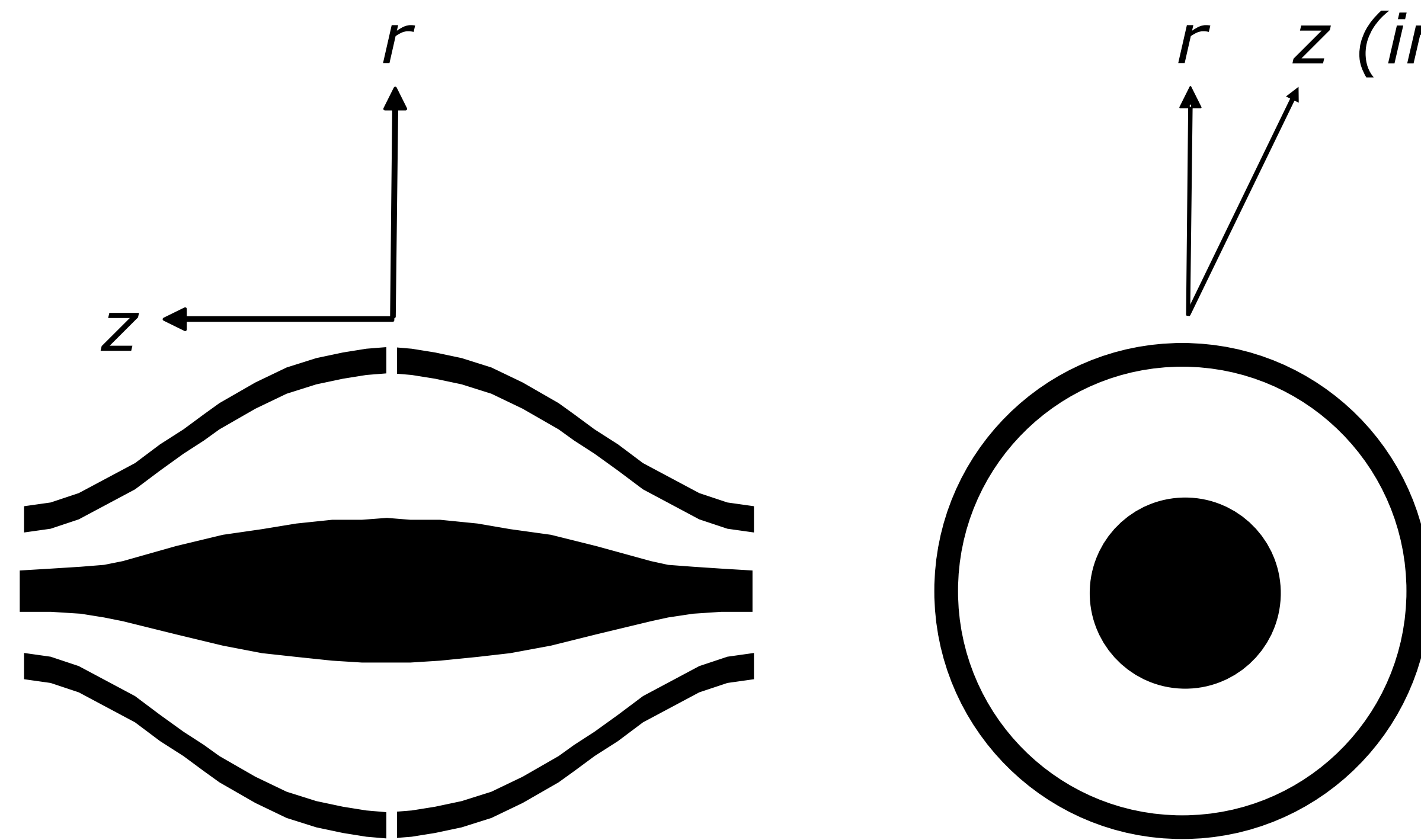

$$E(r, z) = \frac{k_0}{2} \left[ z^2 - \frac{r^2}{2} + R_m^2 \ln \left( \frac{r}{R_m} \right) \right] + C$$

- $E$ , electrostatic potential distribution
- $r, z$ , cylindrical coordinates
- $k_0$ , field curvature constant;
- $R_m$ , characteristic radius (trapped ions must have  $r < R_m$ )
- $C$ , constant potential offset

# Establishing rotational and axial oscillation

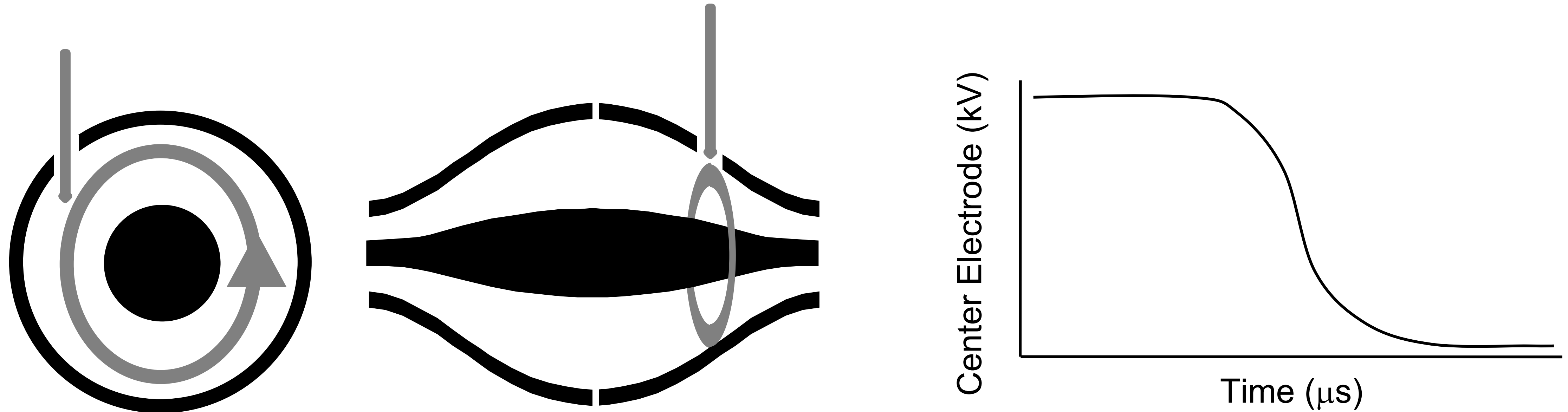

- Ions are rapidly injected as a spatially confined packet at one end of the z axis.
- The center electrode potential is lowered in order to trap the ions in a stable orbit.
- The ions of a given  $m/z$  thus begin their z-axis oscillation with the same phase.

# Different oscillation frequencies

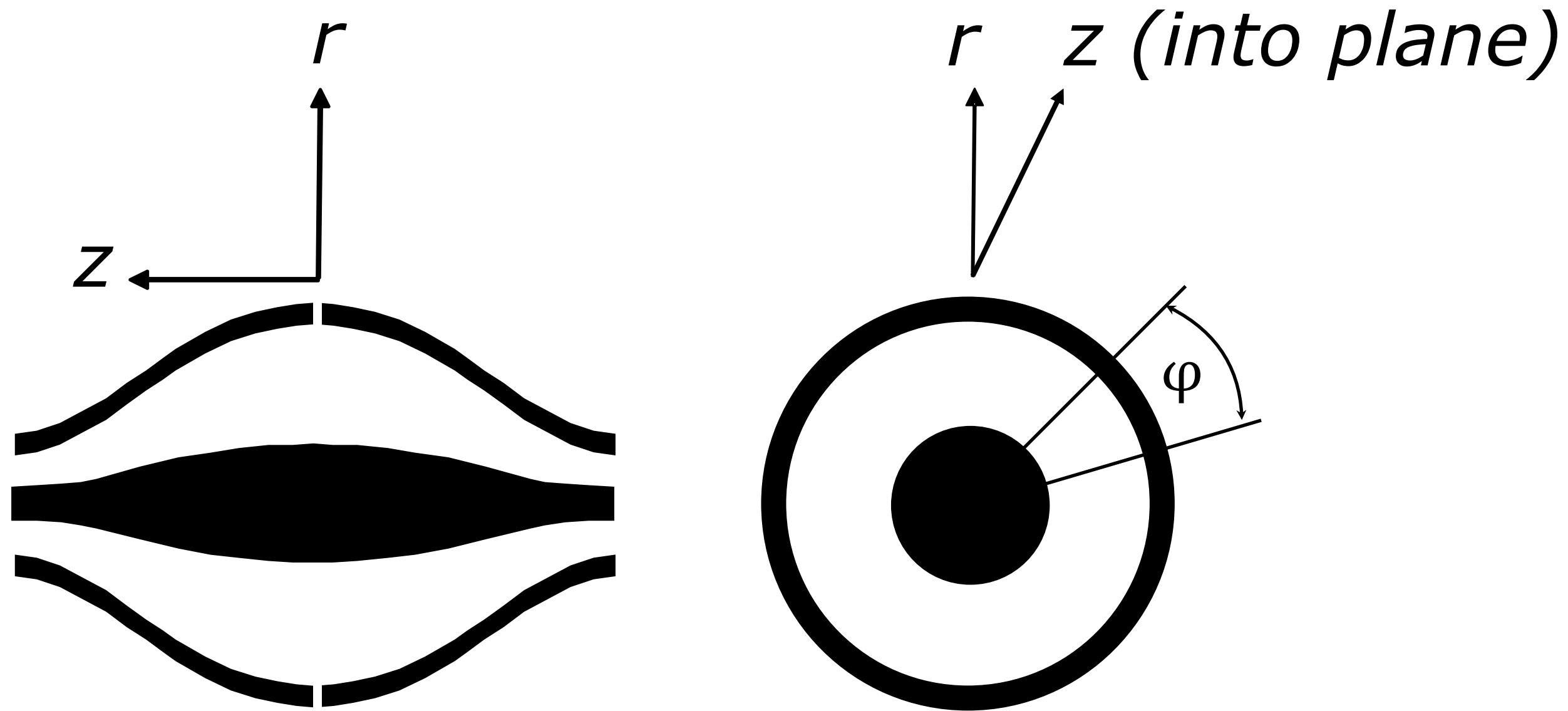

$$R = \frac{m}{\Delta m};$$

**Resolution:**

$$m \propto \frac{1}{\omega_z^2}; \quad dm \propto \left(\frac{1}{\omega_z^2}\right)' d\omega = \frac{-2}{\omega_z^3} d\omega;$$

$$\frac{m}{\Delta m} \propto \frac{1}{\omega_z^2} \frac{\omega_z^3}{\Delta\omega} \propto \omega_z \cdot t \propto \frac{t}{\sqrt{m}}.$$

– Frequency of radial oscillations:  $\omega_r = \omega_z \sqrt{\left(\frac{R_m}{R}\right)^2 - 2}$

– Frequency of rotation:  $\omega_\varphi = \frac{\omega_z}{\sqrt{2}} \sqrt{\left(\frac{R_m}{R}\right)^2 - 1}$

– Frequency of axial motion:  $\omega_z = \sqrt{\frac{k_0 z e}{m}}$

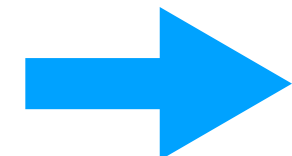

$$\frac{m}{z} = \frac{k_0 e}{4\pi^2 f_z^2}$$

Only this motion depends on m/z !

- ✓ Resolution decreases with m as  $m^{-1/2}$
- ✓ Resolution increases with time of measurements

# Orbitrap ion current detection

- Similar to FT ICR;
- Frequency of axial oscillations

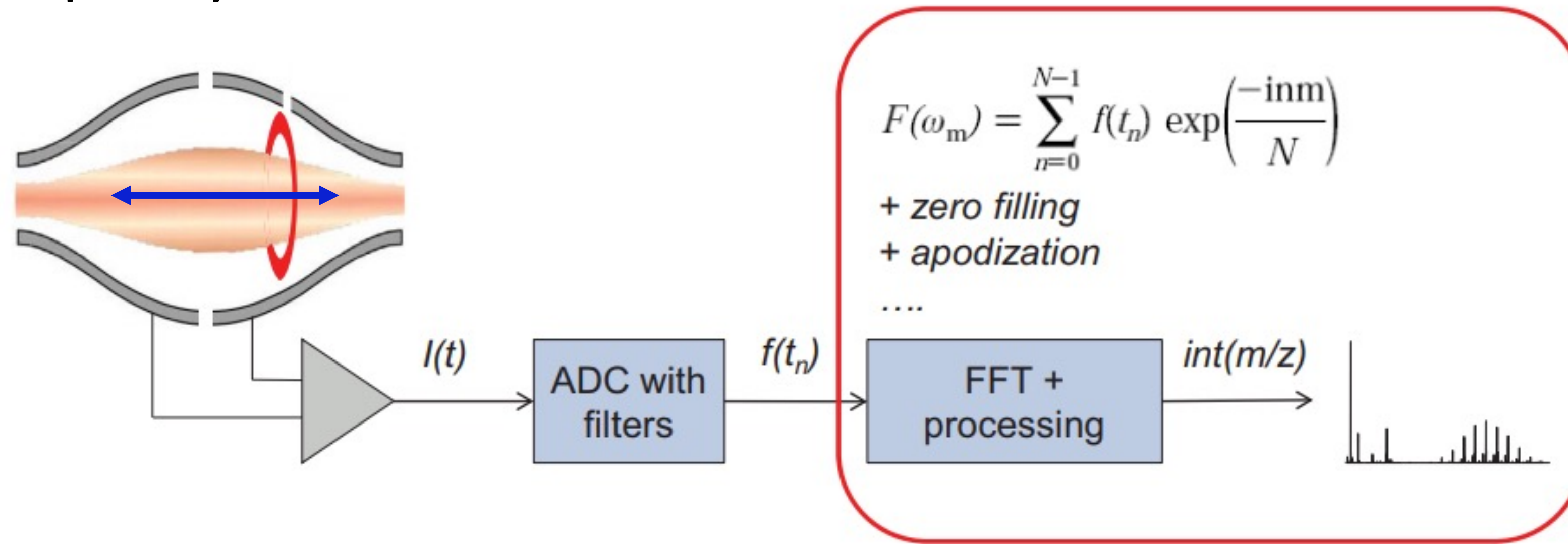

The image current on each half is differentially amplified and undergoes Analog-to-Digital Conversion before FT algorithm

- Fourier Transform is used to convert signal to  $m/z$  data

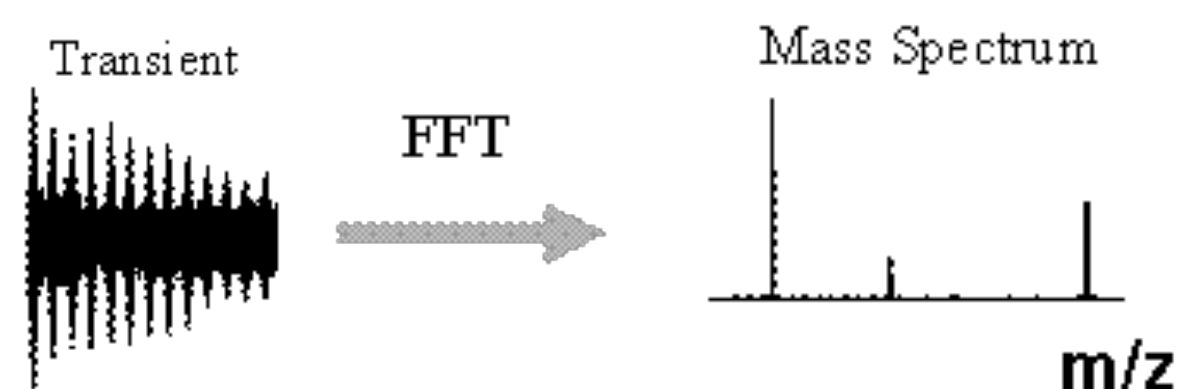

Details of FT will be given in NMR section

# Orbitrap summary

- + High performance instrument competitive with FT-ICR mass analyzers
- + Mass resolving power up to 240'000 at 400  $m/z$
- + Resolution depends on the transient length: 512 ms for 240K on a Q-Exactive HF.
- + High mass accuracy (1 ppm).
- + Compare with ICR: compact: no LHe is required; low cost; low operation cost.
- Requires ultra-high vacuum to realize sufficiently long transients
- Resolving power is directly linked to scan speed (lower scan speed yields better RP)
- RP decreases with increasing  $m/z$

# Fragmentation methods and tandem mass spectrometry

# Tandem mass spectrometry

Problem: How do you distinguish two different molecules of exactly the same mass?

Break them into pieces and analyze the mass of the pieces

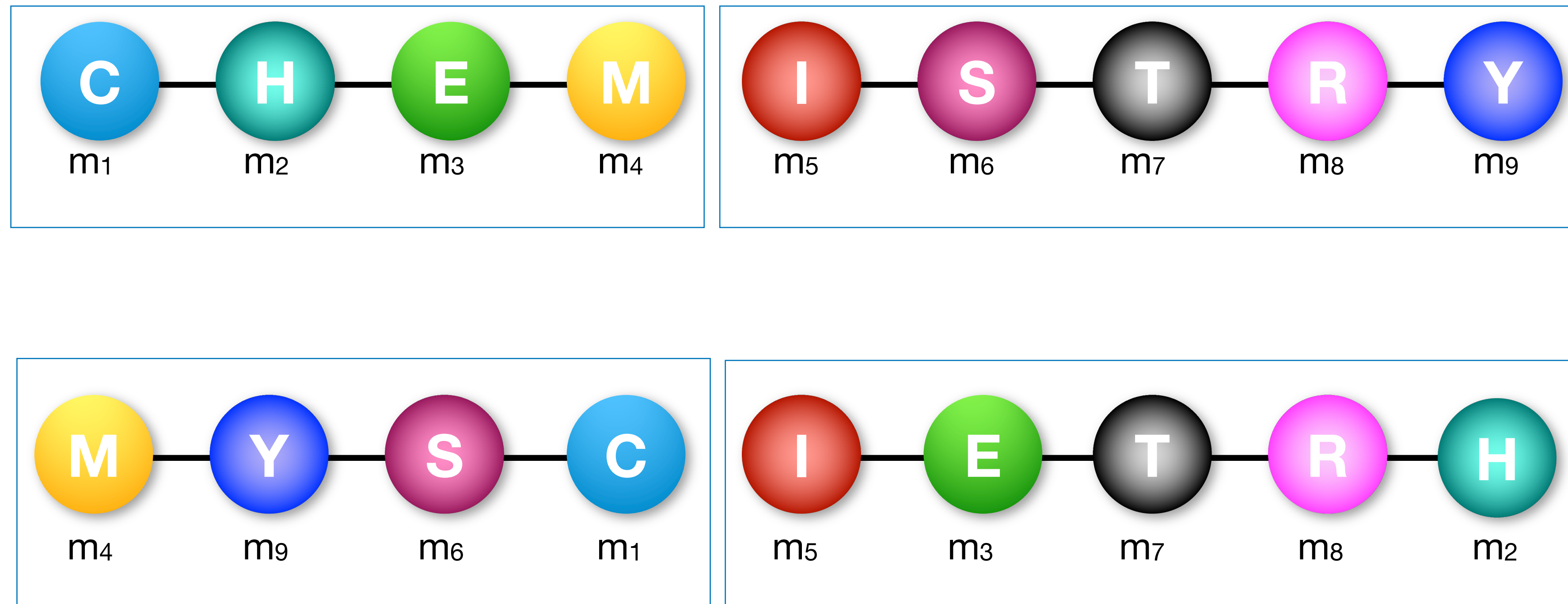

In general, the pieces will have different mass.

# Tandem mass spectrometry

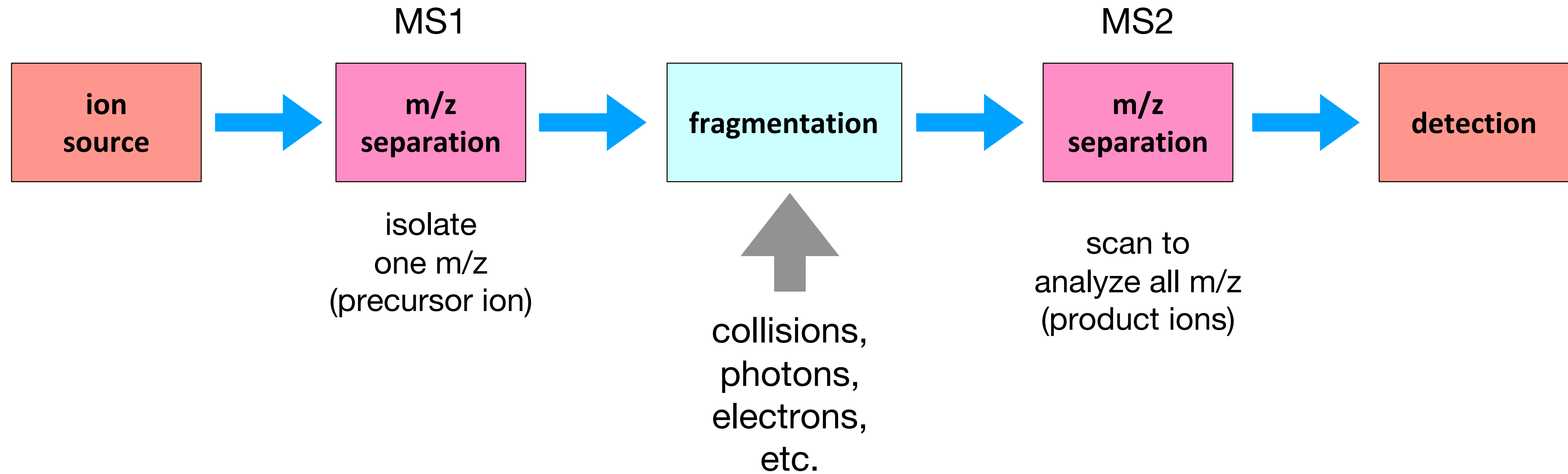

# Fragmentation methods in tandem MS

- Collision Induced Dissociation (CID)
  - Low-energy CID
  - High-energy CID (HCD)
- Surface-induced Dissociation (SID)
- Photodissociation
  - Infrared Multi-photon Dissociation (IRMPD)
  - UV Photodissociation (UVPD)
- Electron Capture Dissociation (ECD)
- Electron Transfer Dissociation (ETD)

Different fragmentation techniques produce different types of fragments, which is useful for structural analysis.

Different MS techniques are best suited to specific fragmentation methods.

# Collision-induced dissociation (CID)

**Low energy:** Energy deposited into a molecule slowly through multiple, low-energy collisions.

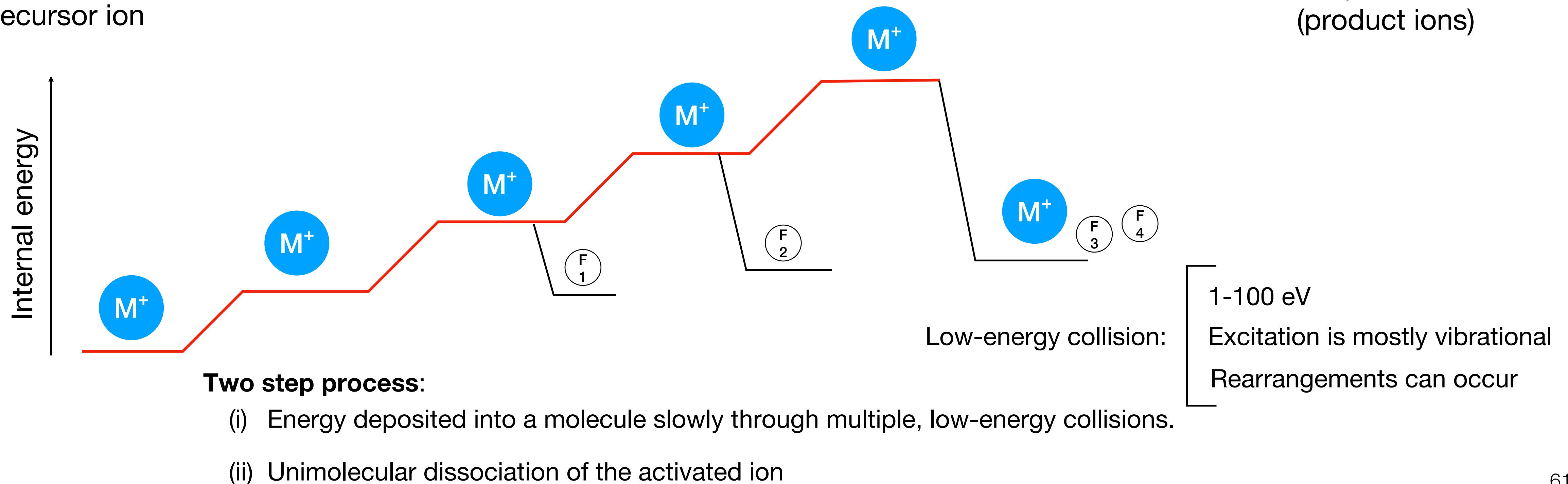
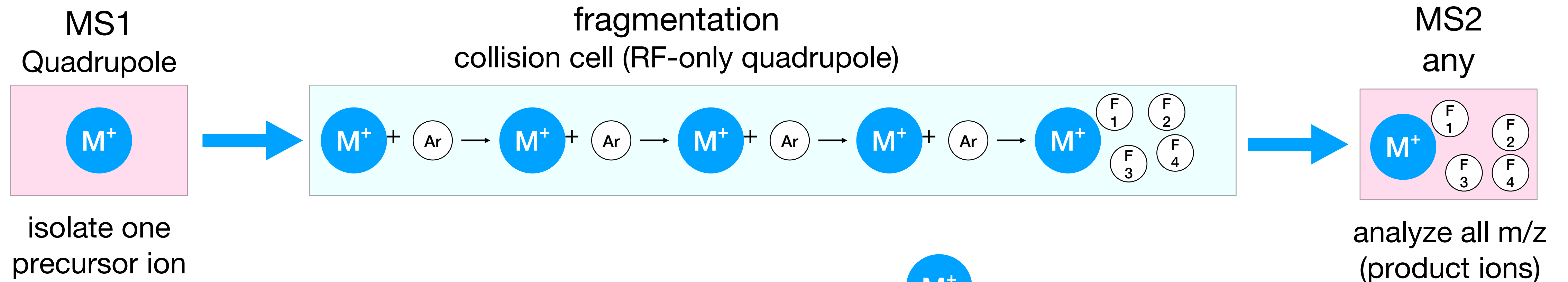

# Electron capture dissociation (ECD)

- ECD involves the capture of low-energy electrons by multiply charged ions, with charge-state reduction and subsequent fragmentation
- Works in FTICR but it is difficult to perform in quadrupole traps, orbitraps, . . .

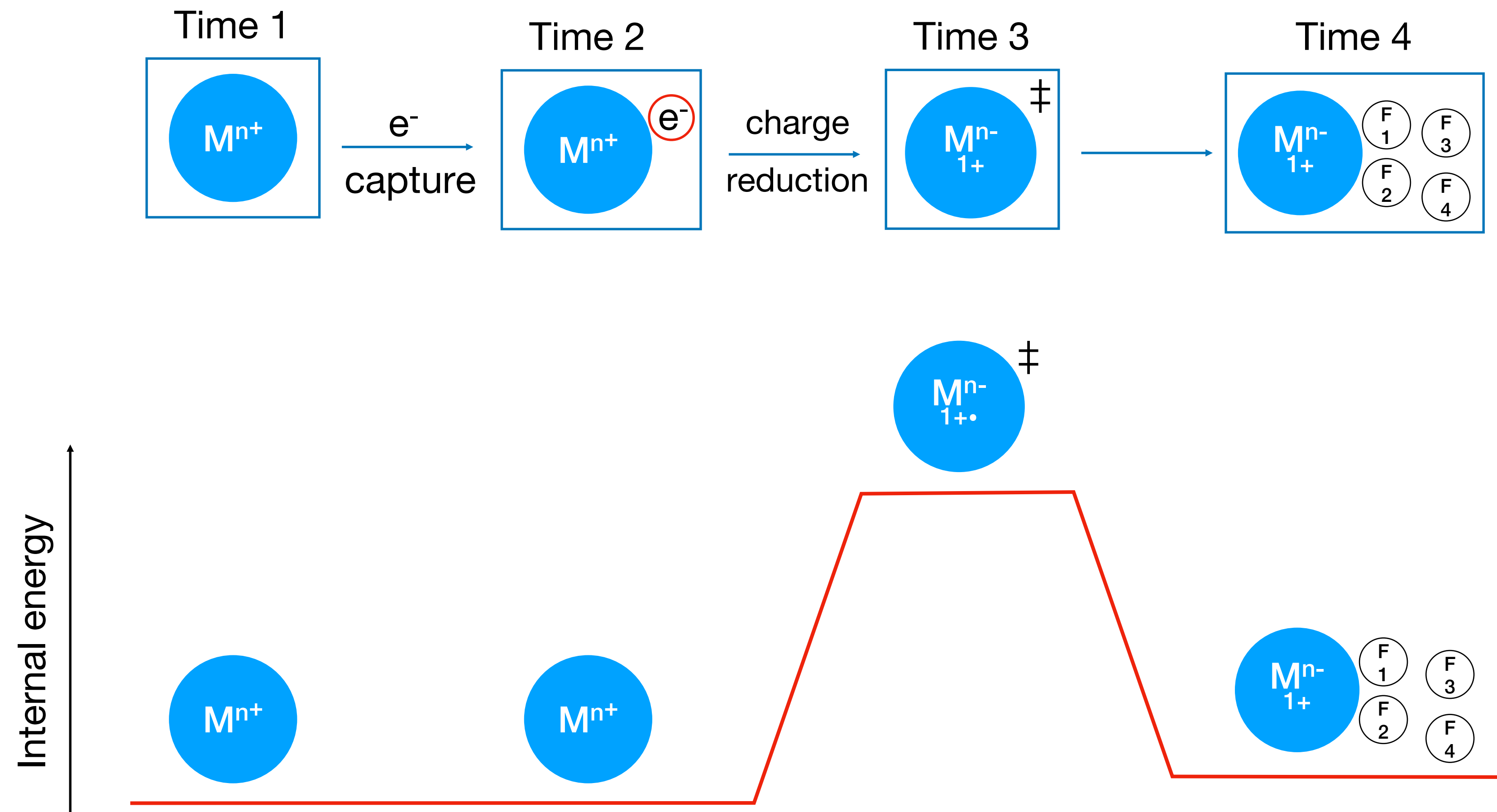

# Photon-induced dissociation

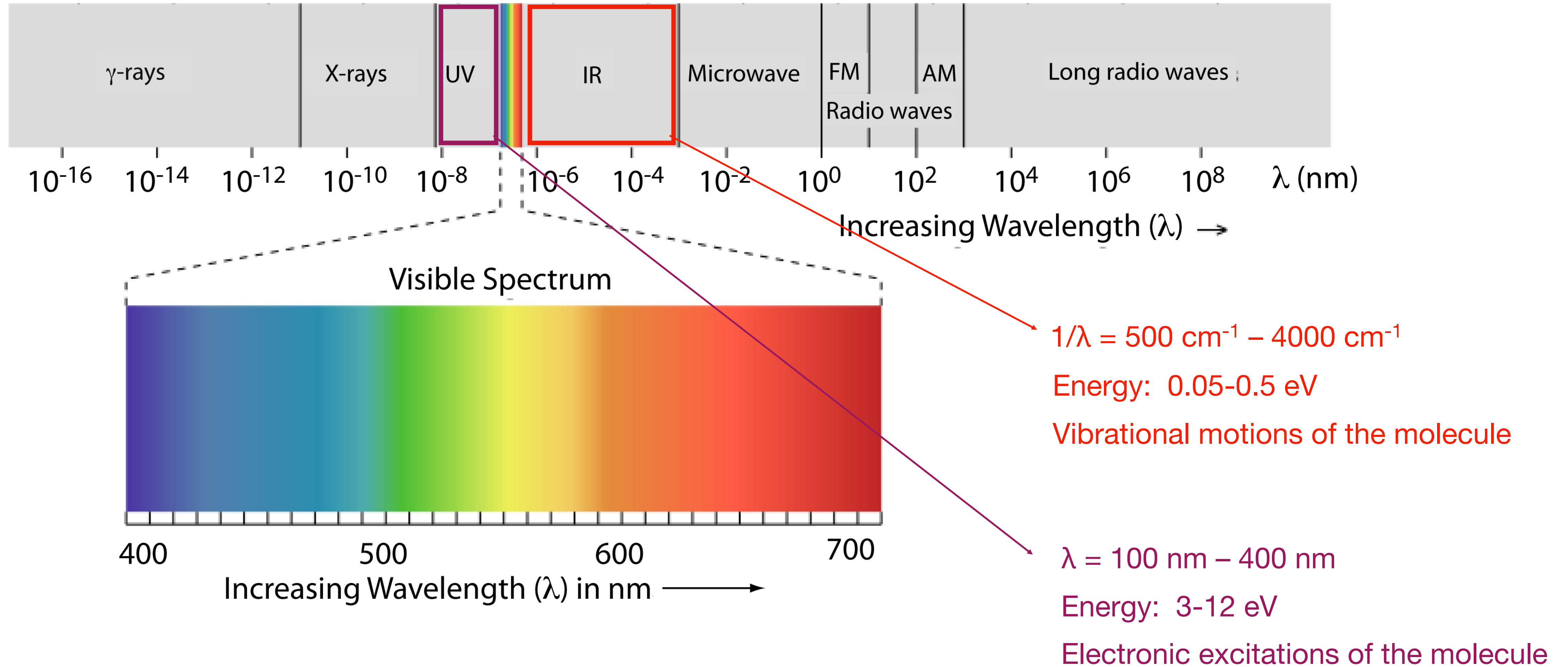

# Infrared multiphoton dissociation (IRMPD)

- Involves excitation of multiple IR photons by IR active modes
- After photon absorption, rapid redistribution of energy over all vibrational degrees of freedom occurs.
- Statistical internal energy distribution (like in CID)

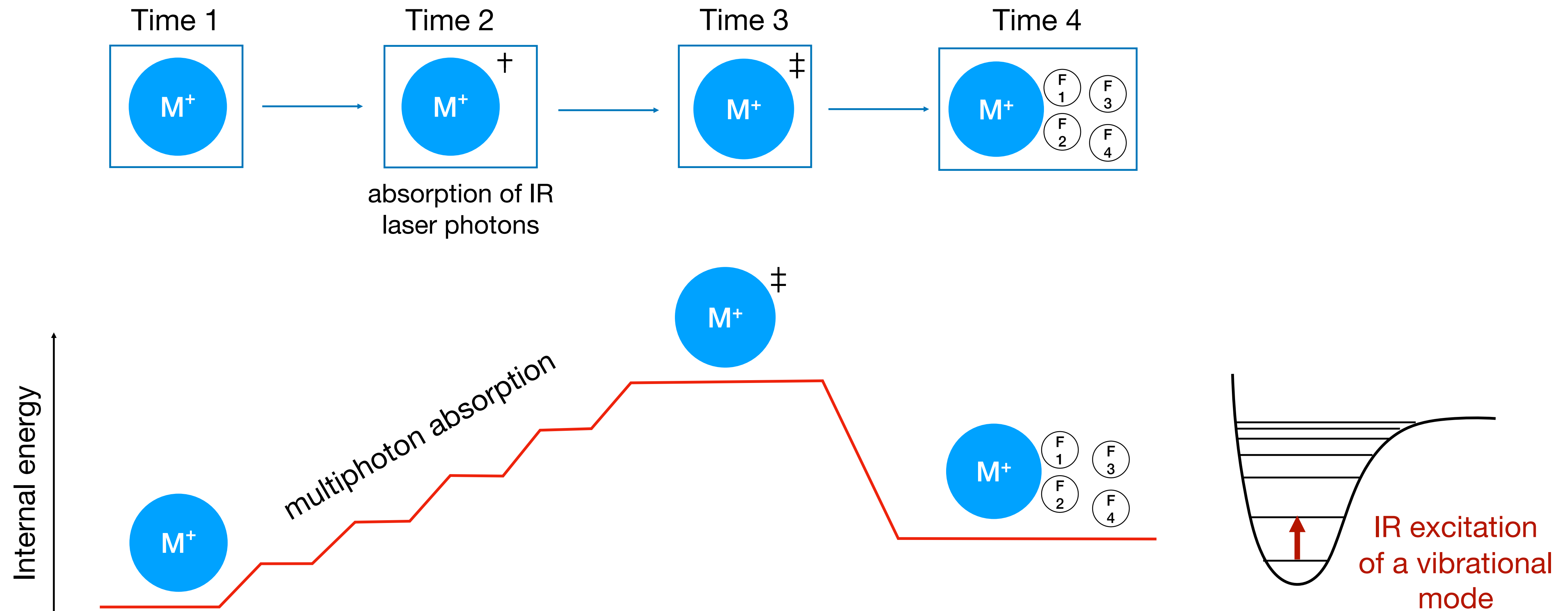

# UV photodissociation (UVPD)

- Activation occurs through the absorption of a single UV photon
- The photon causes a vibronic transition, which is a simultaneous change both in electronic and vibrational state

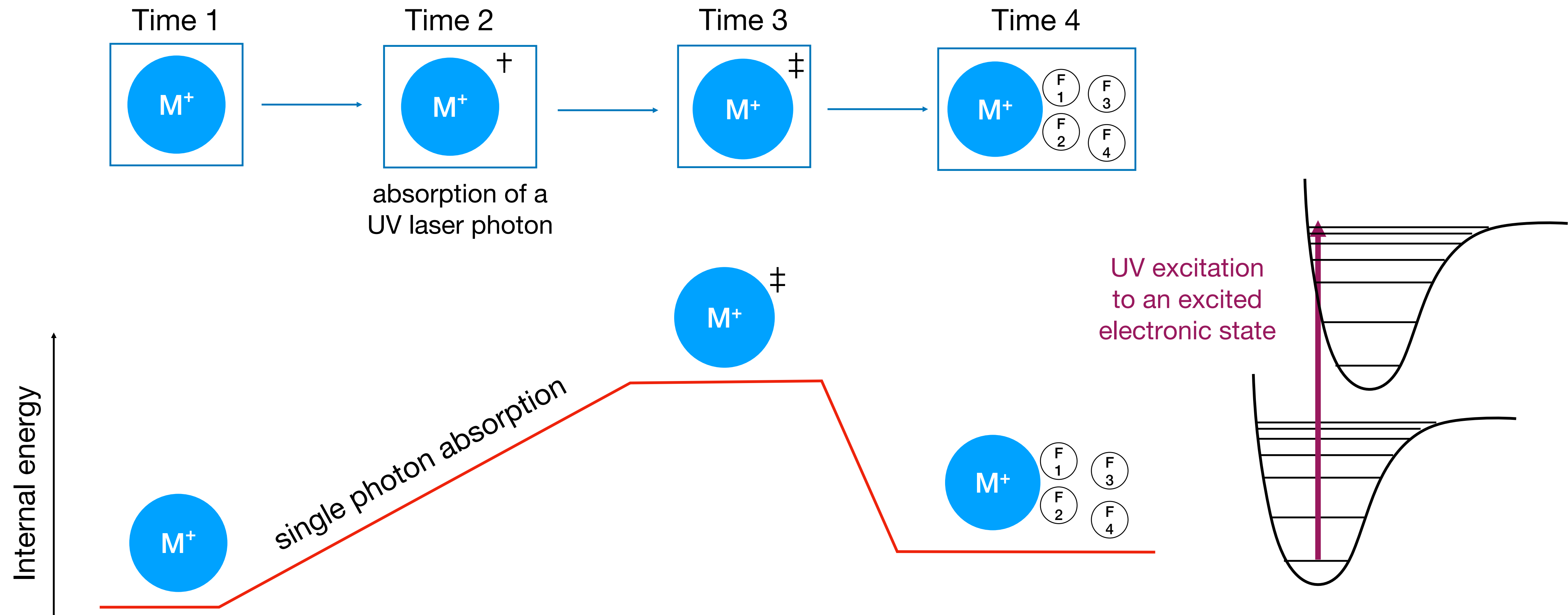

+

## Comparison of fragmentation methods

-

Simple Large diversity of fragments Applicable to any charge state	<b>CID</b>	Unpredictable fragments Loss of PTMs No info on 3D structure
Similar to CID; Retains some PTMs;	<b>HCD</b>	Unpredictable fragmentation Loss of high fraction of PTMs No info on 3D structure
Similar to CID, but doesn't require collisions; Can be wavelength selective;	<b>IRMPD</b>	The same as for CID; Technical complexity
Non-statistical, gives specific fragments; Retains PTMs, reflects 3D structure + Highly specific to ions/isomers	<b>UVPD</b> <b>UVPD-MS</b>	Technical complexity Moderate dissociation yield Additional technical complexity
Cleaves very wide types of bonds; High fragment abundance; Retains some PTMs;	<b>VUVPD</b>	Technical complexity; No info on 3D structure
Non-statistical, highly predictable bond cleavage (c, z fragments); Retains most of PTMs	<b>ETD/ECD</b>	Low efficiency; Not applicable to singly-charged and negative ions; Very limited info on 3D structure

# Peptide structure

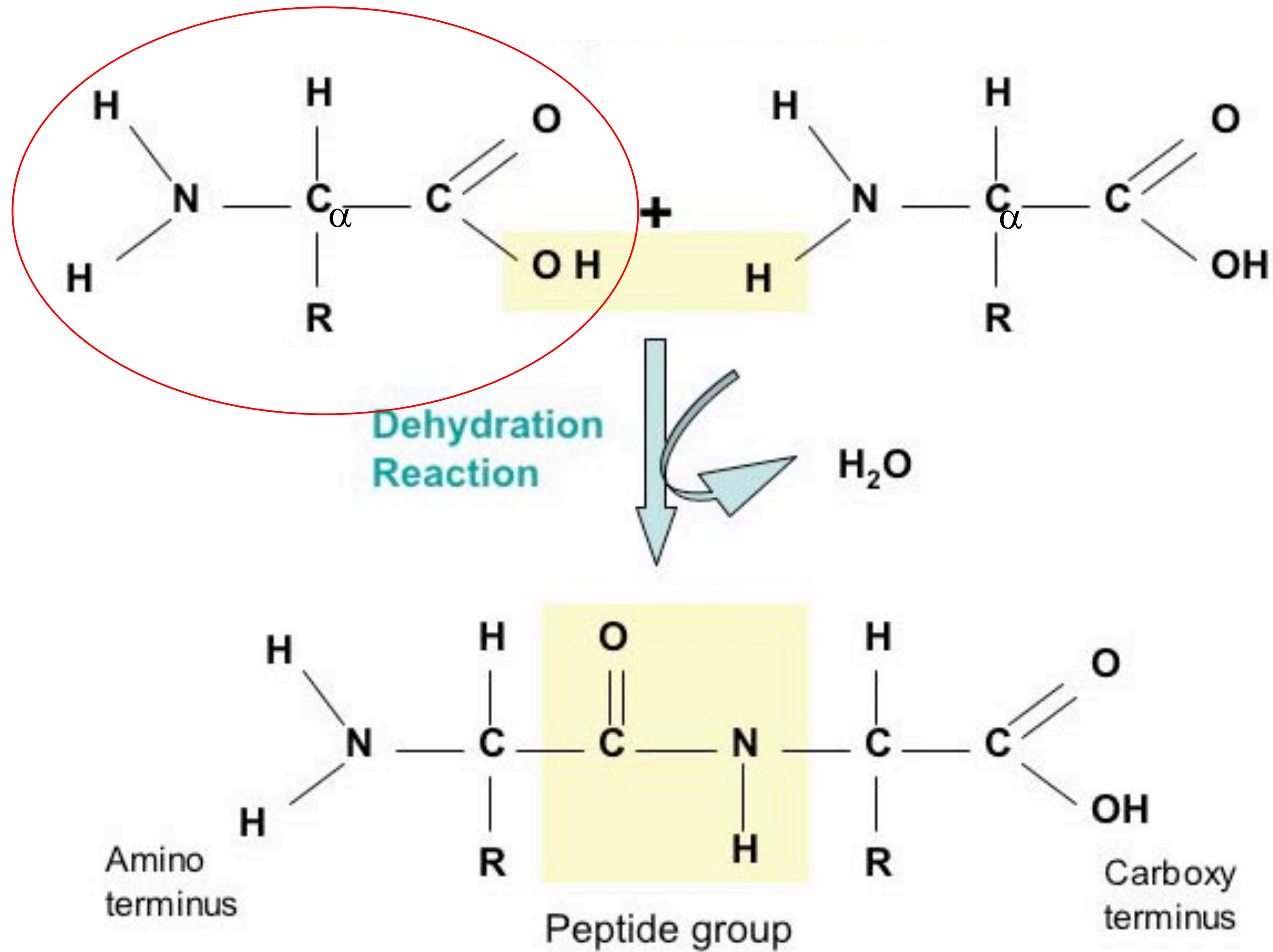

# Tandem MS of peptides and proteins

## Nomenclature for peptide fragments:

For x, y, and z fragments, the charge remains on the fragment to the right.

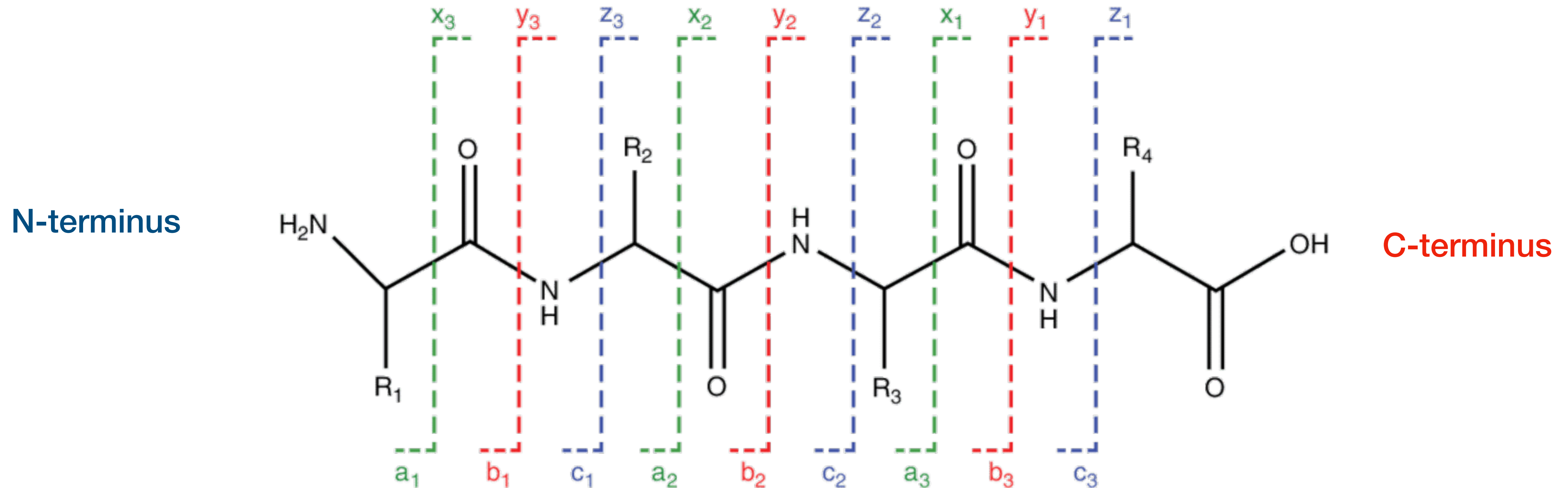

For a, b, and c fragments, the charge remains on the fragment to the left

# Peptide fragmentation

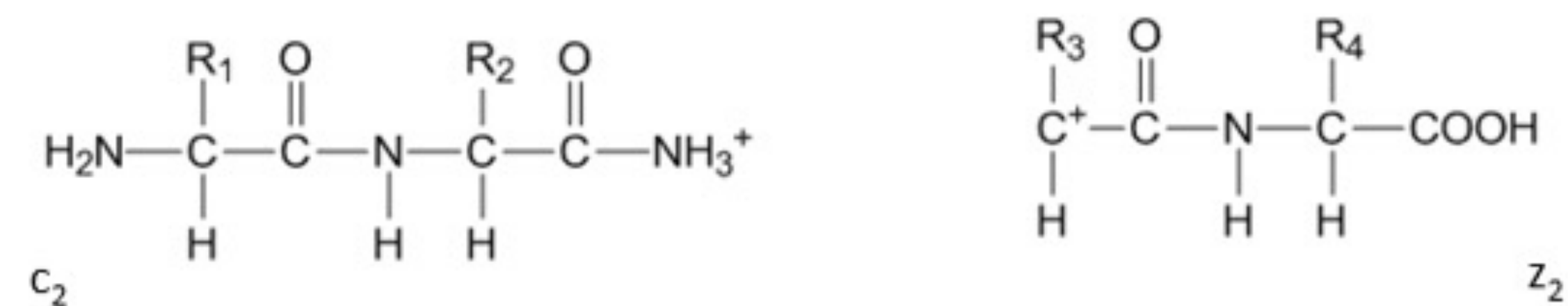
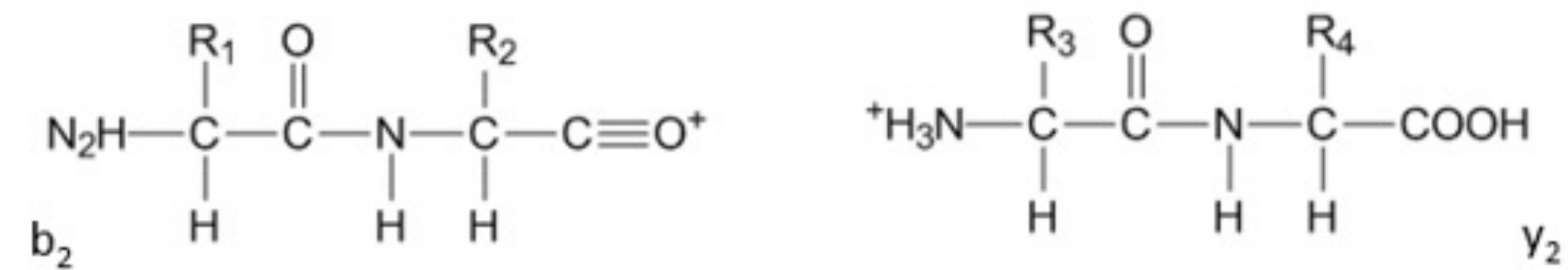
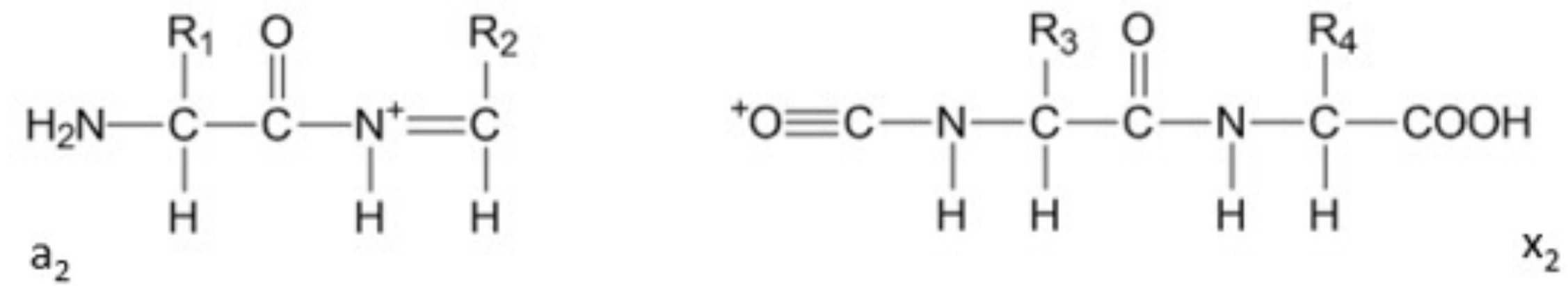
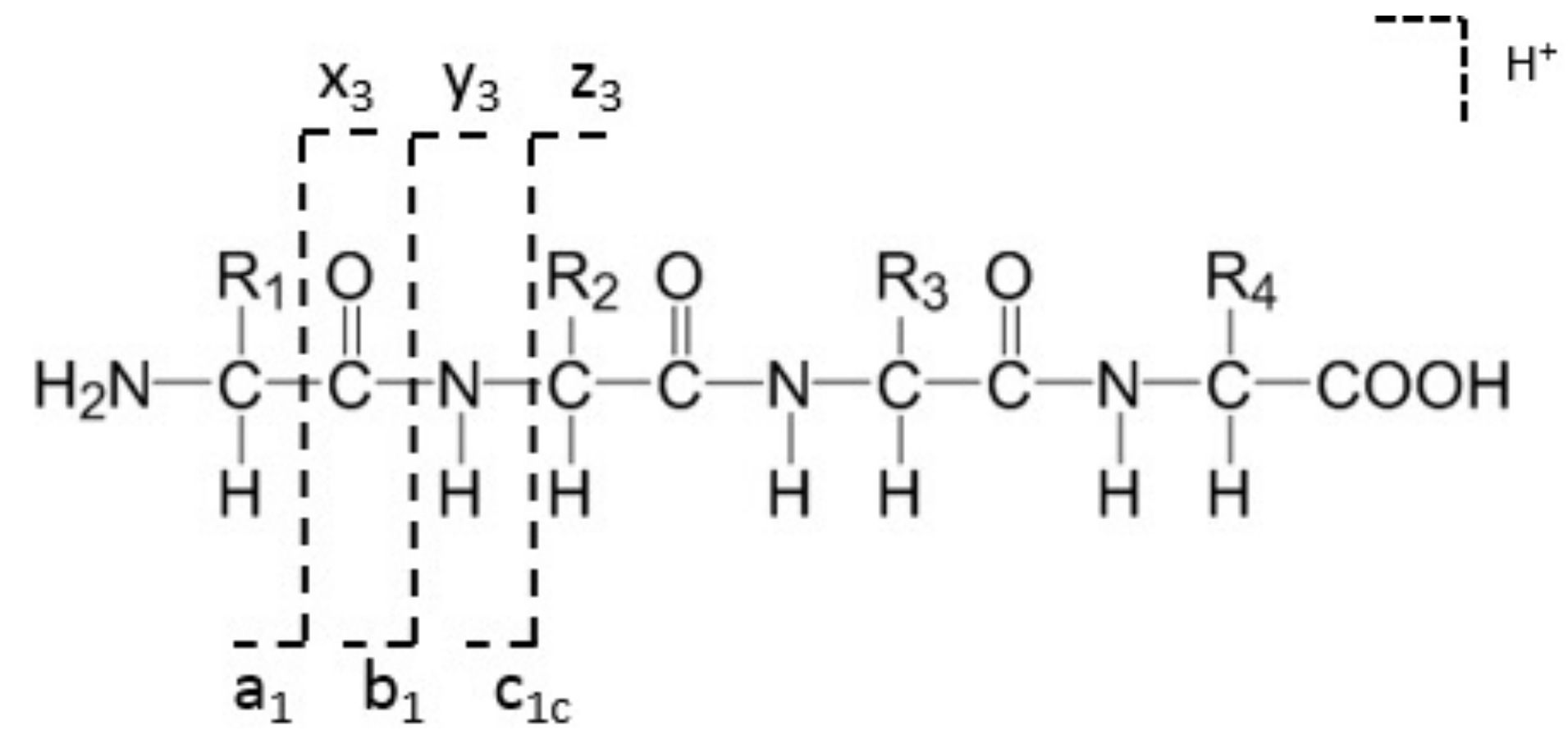

# Peptide fragmentation

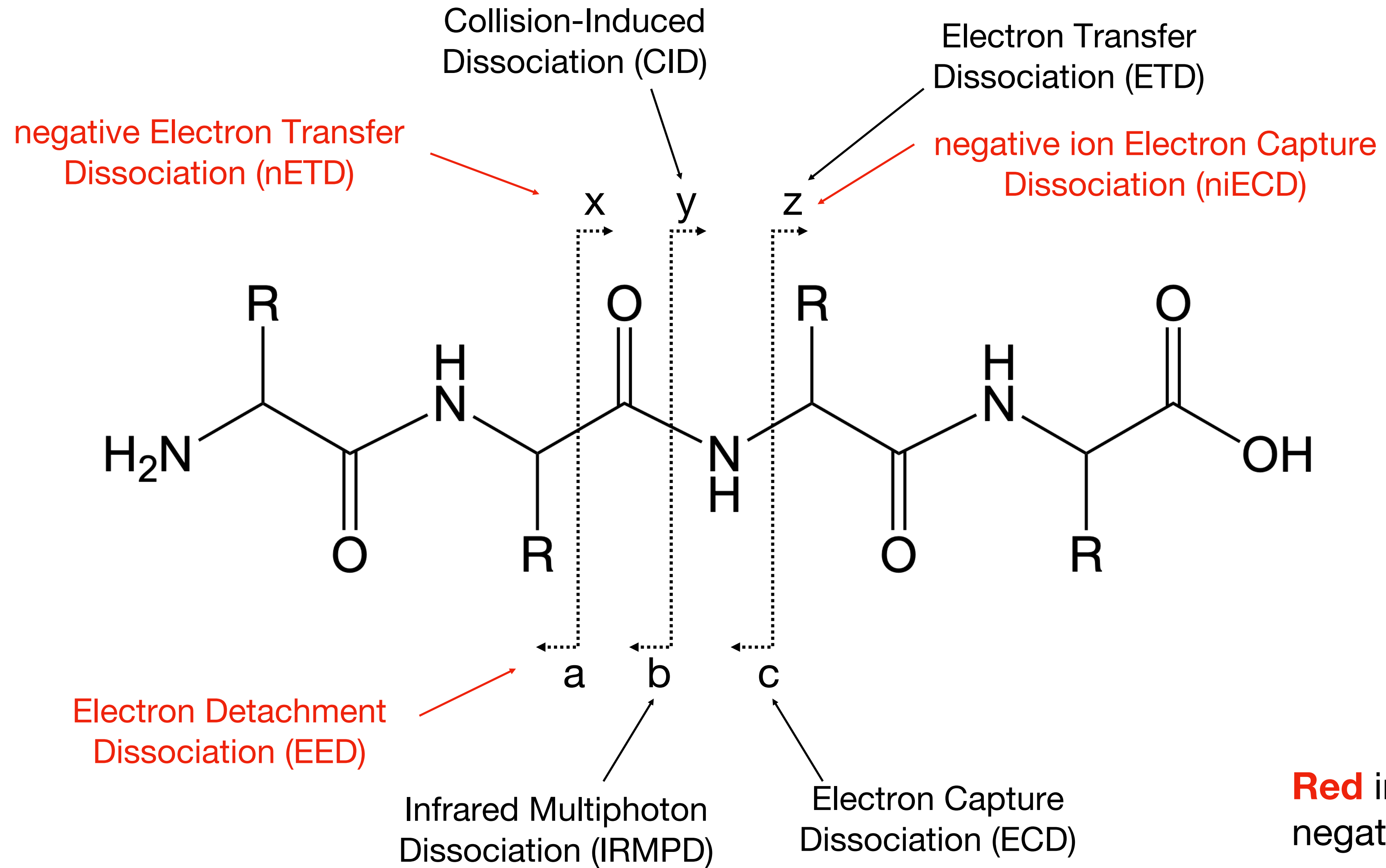

# How to calculate b/y fragments

$b_n$

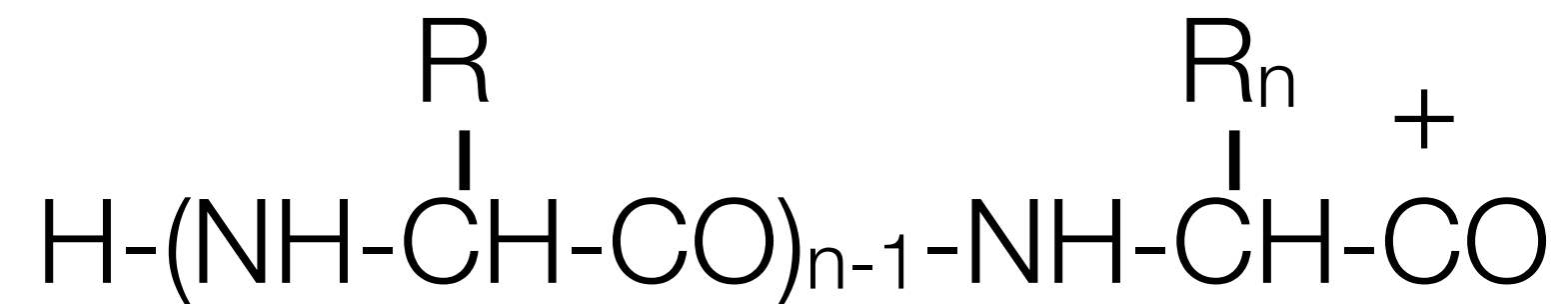

$$\begin{aligned} m(b_n) &= \\ &= \sum_{i=1}^{n-1} m(R_i + C_2H_2NO) + \\ &+ m(R_n) + m(C_2H_3NO^+) \end{aligned}$$

Enumeration starts from N-terminus

$y_n$

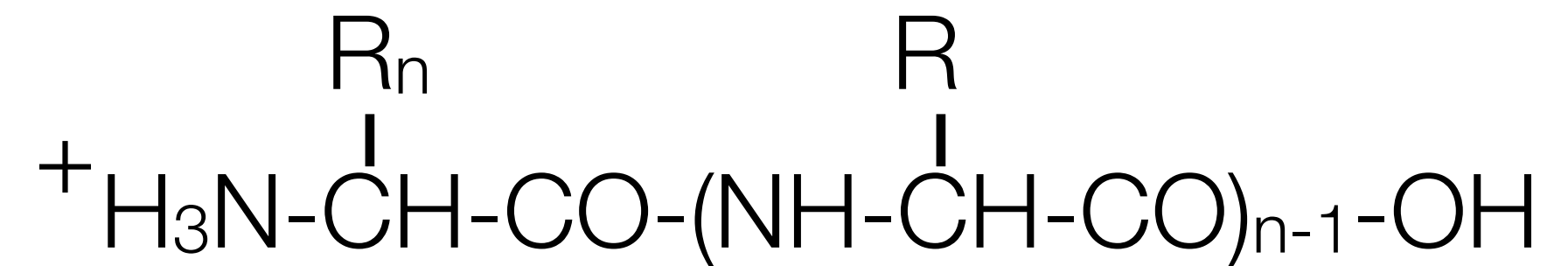

$$\begin{aligned} m(y_n) &= \\ &= \sum_{i=1}^{n-1} m(R_i + C_2H_2NO) + \\ &+ m(R_n) + m(C_2H_5NO_2^+) \end{aligned}$$

Enumeration starts from C-terminus

*Hydrogen jumps to y-side*

# Cyclotron radius

$$qvB = \frac{mv^2}{r} \quad \longrightarrow \quad r = \frac{mv}{zeB}$$

*Radius of cyclotron motion*

$r$  is proportional to the velocity of ions  $v$ , which at equilibrium depends on  $kT$  (Boltzmann constant)

$$\frac{mv^2}{2} = kT$$

$$r = \frac{1.0336510 \cdot 10^{-6}}{zB} \sqrt{mT}$$

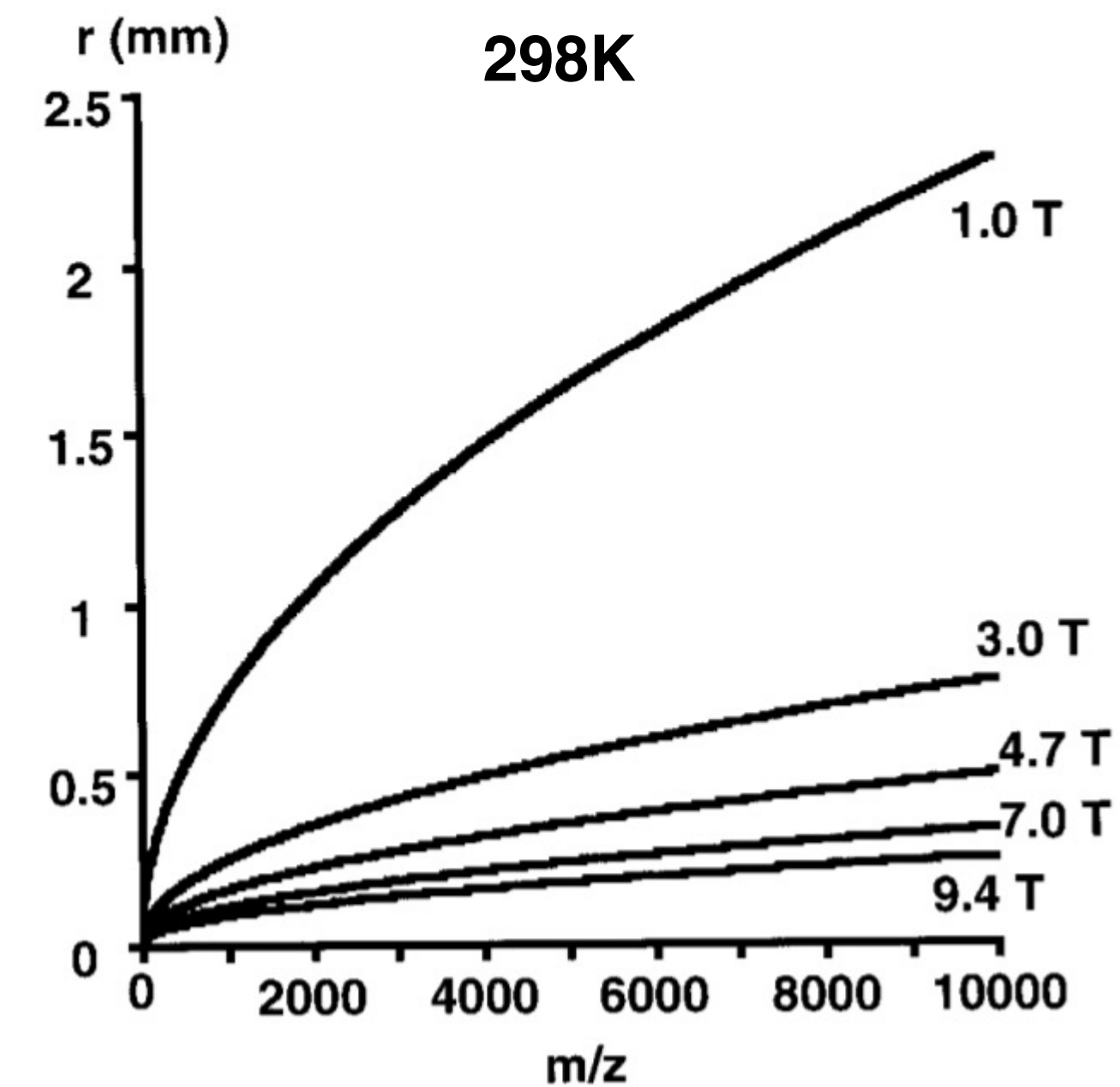

# Principles of ICR

- Different ICR cell geometries

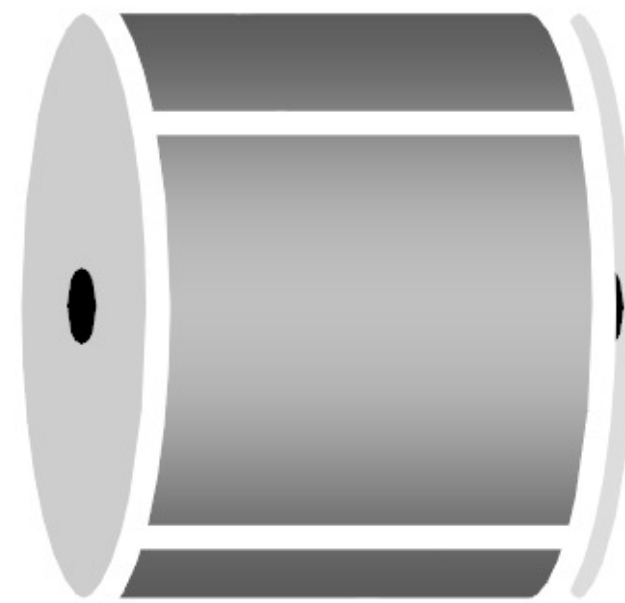

cylindrical

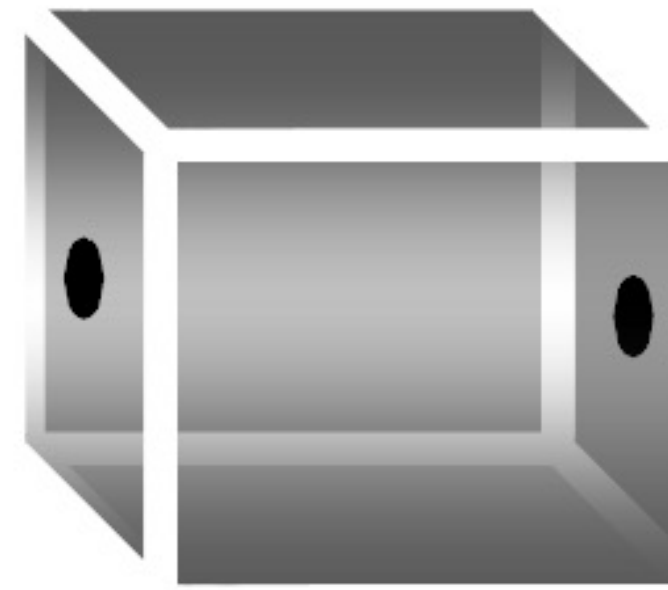

cubic

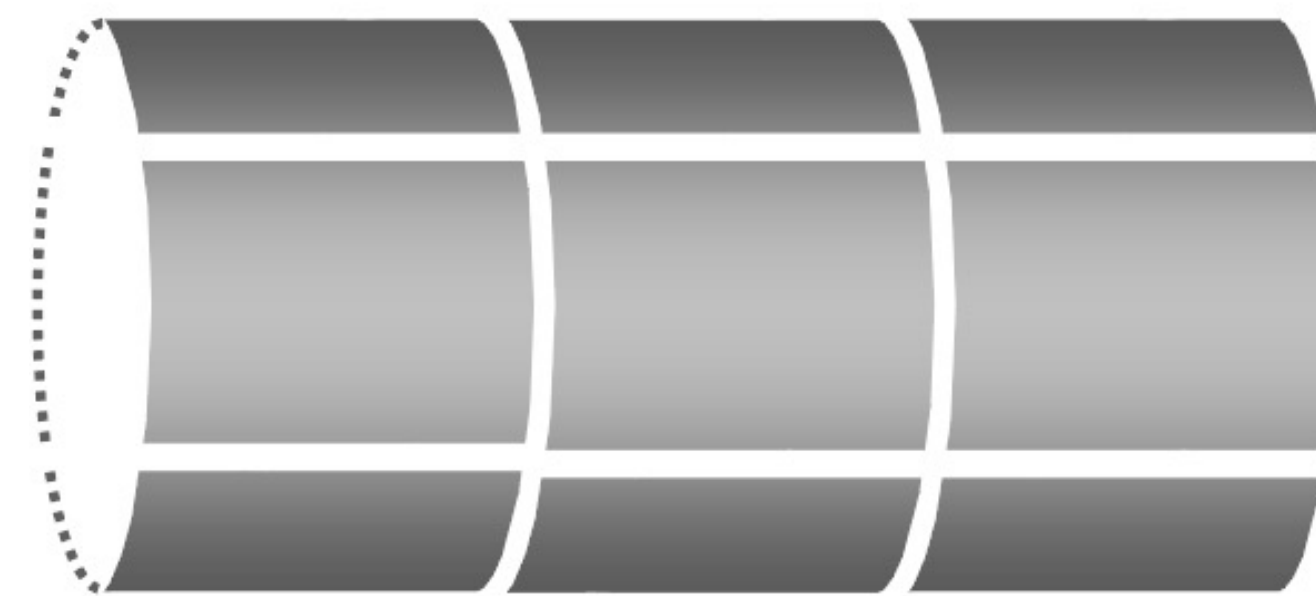

Segmented cylindrical

- Discrete packet of ions enter the ICR analyzer
- A homogenous static magnetic field surrounds the cell
- Very high vacuum in the entire analyzer region

# ICR cylindrical segmented cells



Superconducting  
Magnet (3 to 21T)

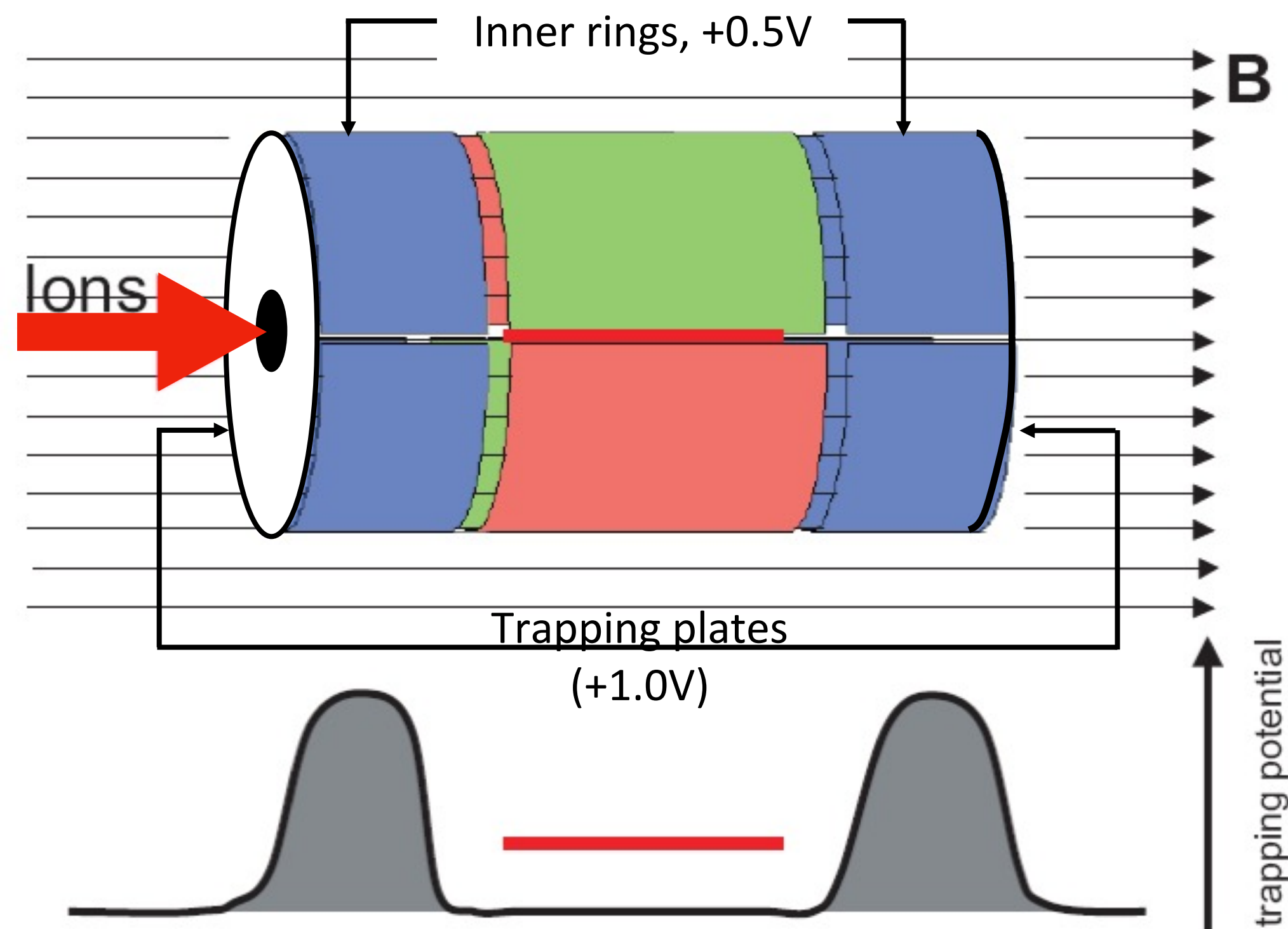

2 excitation electrodes

2 detection electrodes

# ICR: ion excitation

- A sinusoidal pulse (AC) at the same frequency  $f_c$  of the  $m/z$  ion is applied on the 2 **excitation** electrodes

- Resonance radial acceleration of ions by AC electric field increases kinetic energy (and velocity) of ions with  $m/z = \frac{eB}{\omega_{exc}}$

- These ions move together in small clouds (coherently) on orbits with large  $r$  close to detection plates

- Ion with other  $m/z$  cannot absorb the energy and remain in the center of the ICR cell

- *Movement in clouds and close to detection plates is crucial for detection;*
- *Excitation is coherent because  $E_{exc} \gg kt$*

ICR with resonant excitation would work only for one particular  $m/z$  at time !

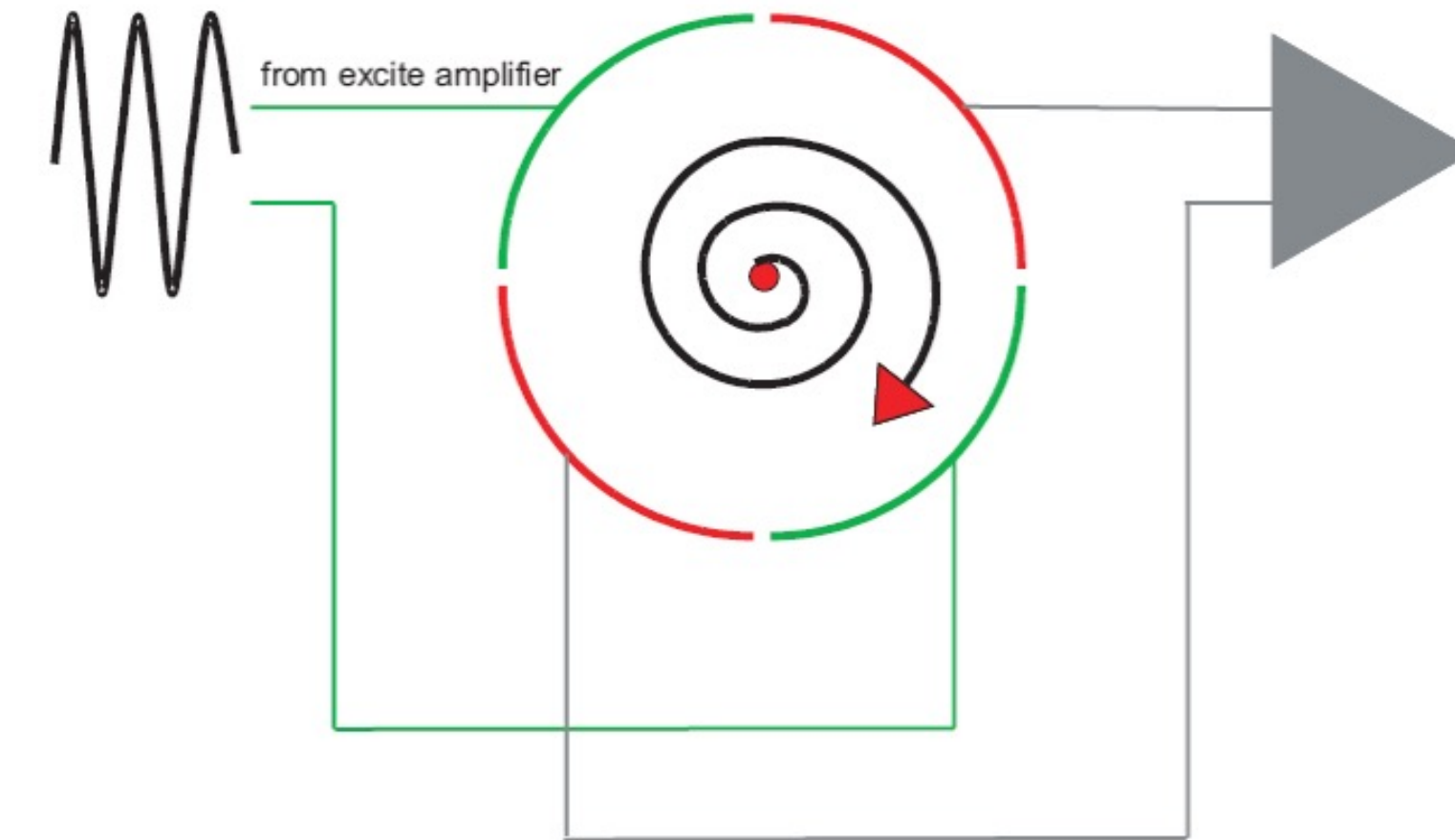

# Ion Cyclotron Resonance mass spectrometer

$$\omega = \frac{q}{m} B$$

- Movement of an ion induces alternating current through resistor

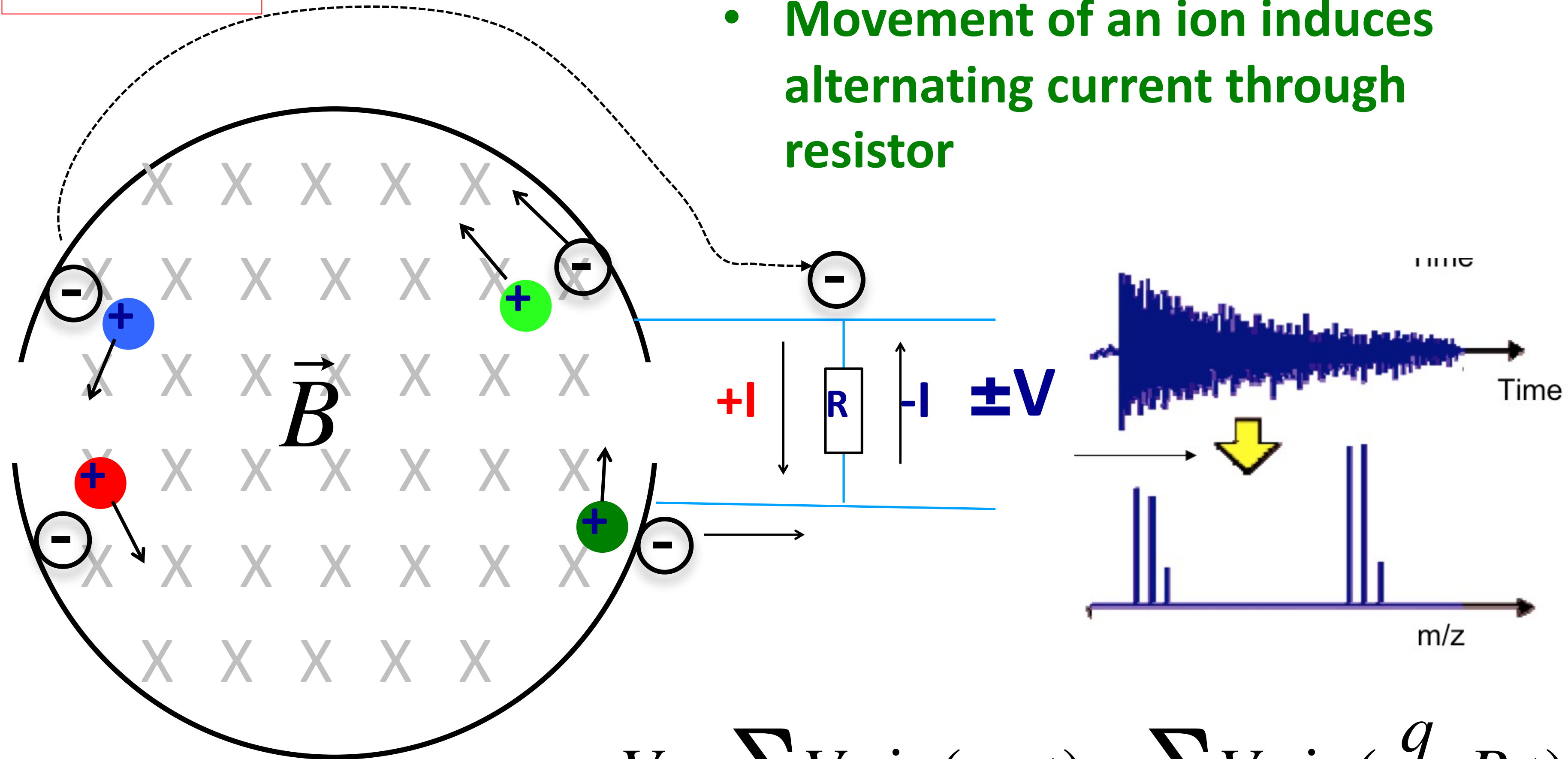

$$V = \sum V_i \sin(\omega_i \cdot t) = \sum V_i \sin\left(\frac{q}{m_i} B \cdot t\right)$$

# Fourier Transform

Time-domain frequency-domain

$$H(f) = \int_{-\infty}^{+\infty} h(t) \cdot e^{2\pi i f t} \cdot dt \xrightleftharpoons[iFT]{FT} h(t) = \int_{-\infty}^{+\infty} H(f) \cdot e^{-2\pi i f t} \cdot df$$

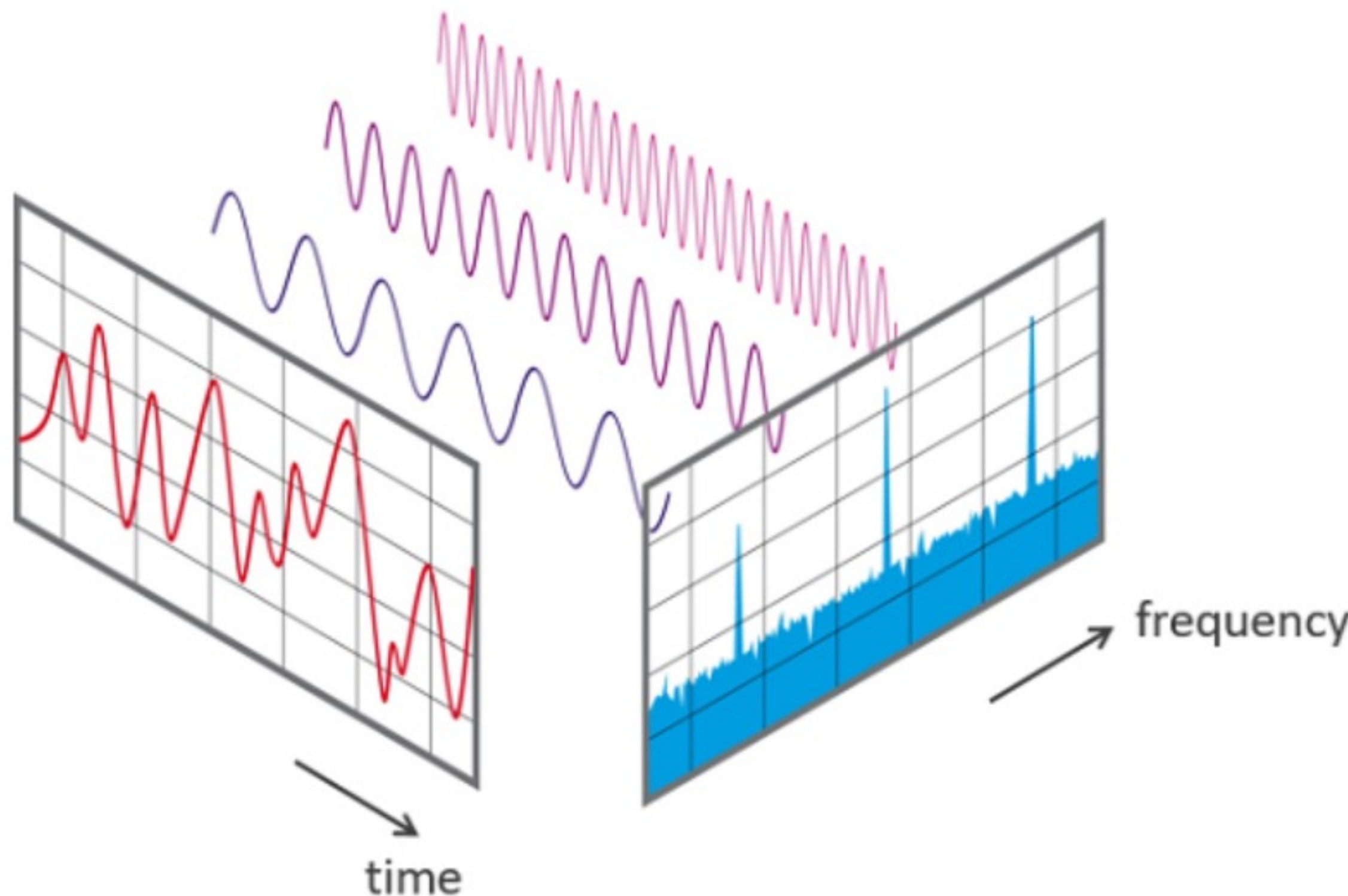

FT is a linear operation. The transformation of the sum of several functions is equal to the sum of the transforms



*broadband transients*

<http://www.youtube.com/watch?v=a5aLm9q-Xc&NR=1>

# Summary of FTMS Work

Broadband excitation

10 MHz      10 kHz

RF Sweep

1. Excitation

Transient Image  
current detection

2. Transient

High Resolution  
(~50,000 FWHM)

3. Fourier-Transform

↓ FFT  
↓ Calibrate

High mass accuracy  
(~1 ppm)

High sensitivity  
(femtomoles)

Mass Spectrum

$RP \cong f \cdot t / 2$   
Sensitivity;  $f \cdot t$

600      800      1000      1200      1400      1600  
 $m/z$

# Resolution of ICR

Cyclotron frequency:  $\omega_c = \frac{qB}{m}$

$$R = \frac{m}{\Delta m}; \quad \frac{m}{q} = \frac{B}{\omega}; \quad \Delta m \simeq dm \propto d\left(\frac{1}{\omega}\right) = -\frac{d\omega}{\omega^2}; \Rightarrow$$

$$R \propto \frac{1}{\omega} \cdot \frac{\omega^2}{\Delta\omega} \propto \frac{\Delta t}{m}.$$

- Resolution of ICR drops linear with  $1/m$
- Resolution of ICR increases with observation time  $t$

# ICR capabilities

- High-performance mass analyzer
- Resolving power  $>200'000$ , typically 500K, drops as  $1/m$ ; increases almost linear with time
- High mass accuracy ( $\approx 1$  ppm)
- Requires ultra-high vacuum ( $<10^{-10}$  mBar)
- Limited number of ions in the cell ( $10^6$ ): limited dynamic range
- Expensive ( $> 1M$  \$)

# What Could We Do With Ions In The orbitrap?

## Image current detection

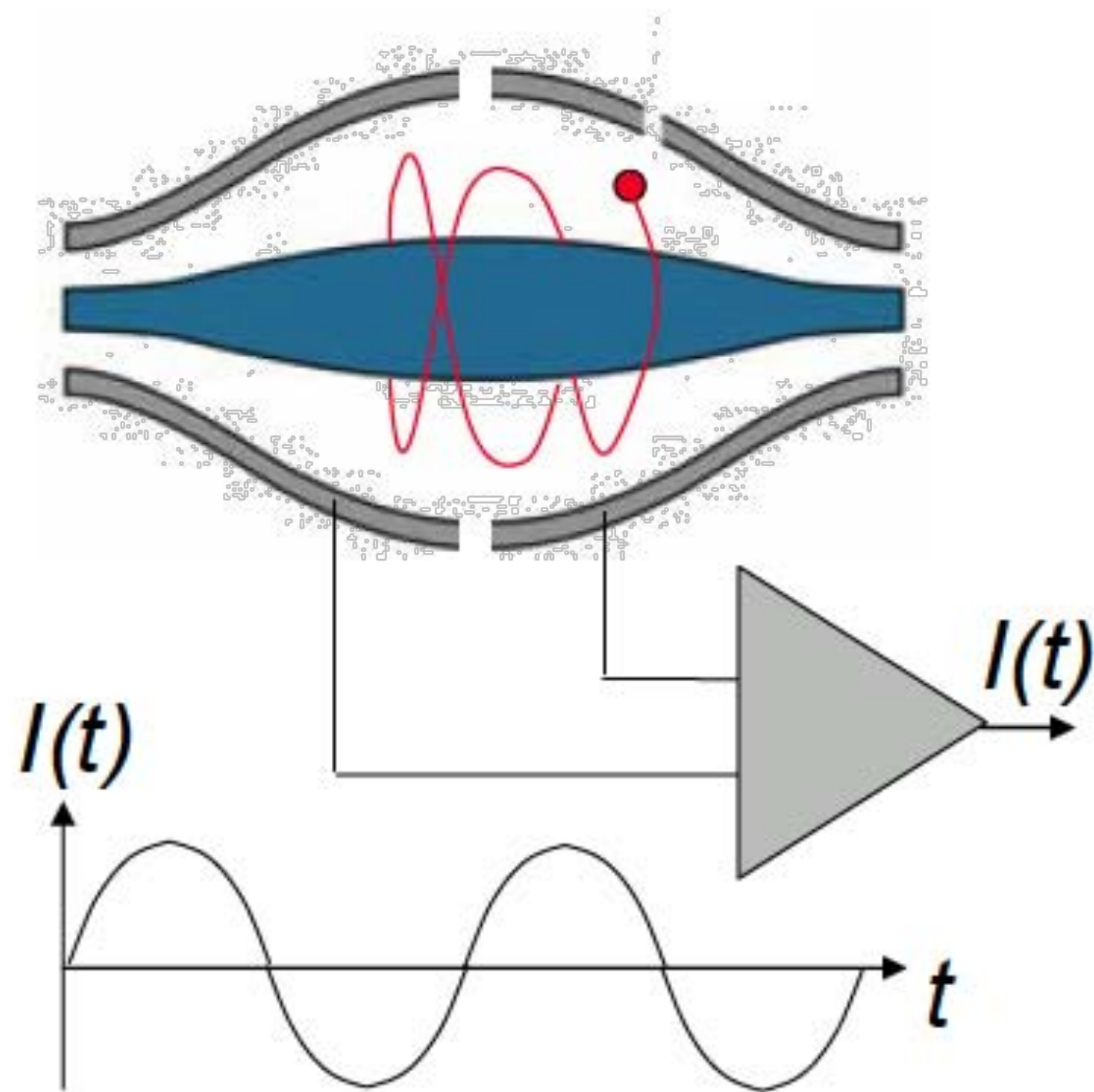

**Notes:**

- All-mass detection
- Noise equiv. to 20 ions (1 sec)



## When the size does matter !

First published theory: 1981;  
First instrument: 2006.

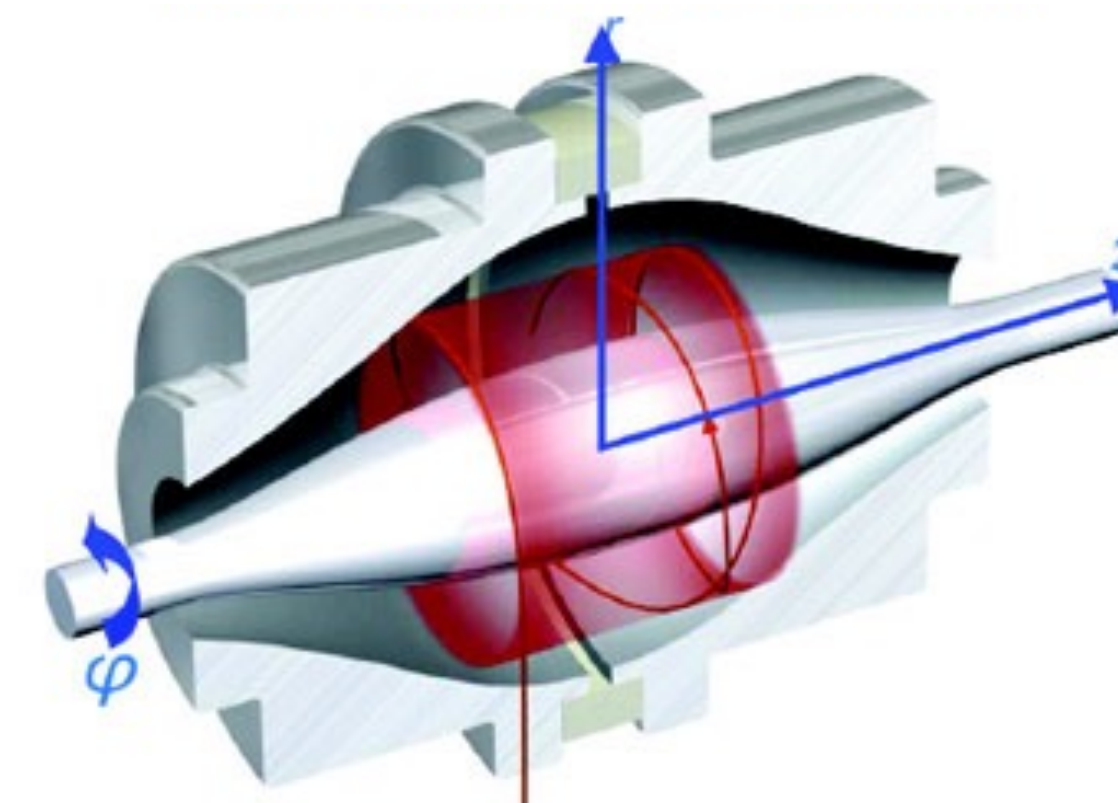

# Electrostatic field in the orbitrap

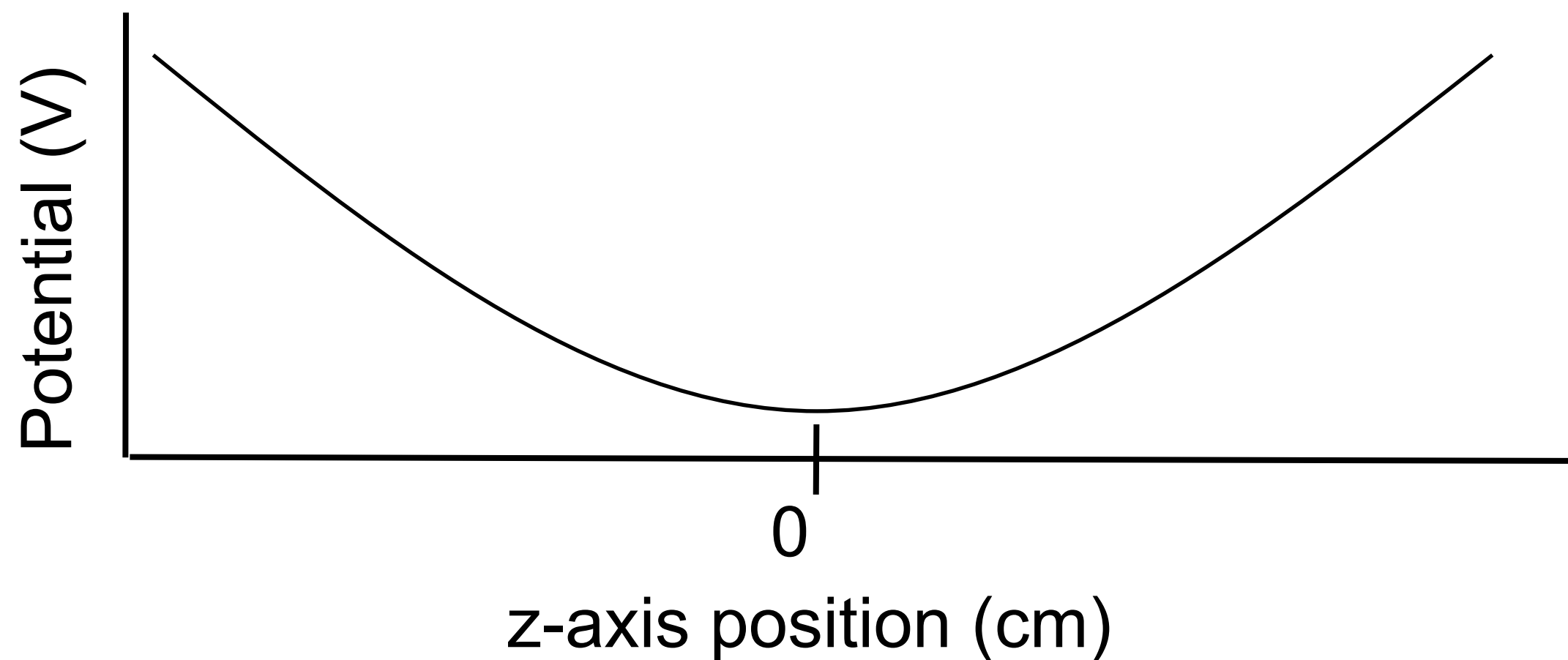
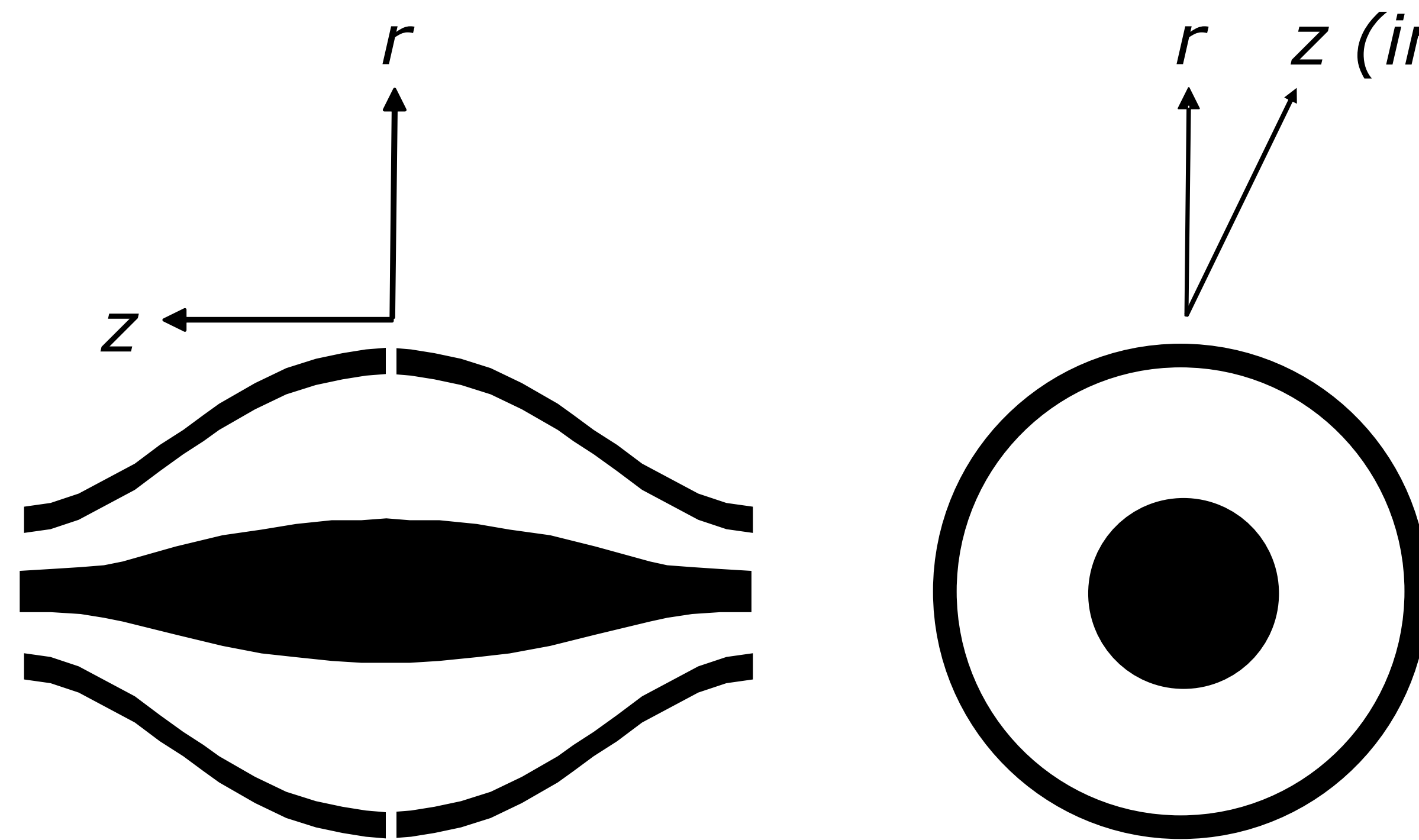

$$E(r, z) = \frac{k_0}{2} \left[ z^2 - \frac{r^2}{2} + R_m^2 \ln \left( \frac{r}{R_m} \right) \right] + C$$

- $E$ , electrostatic potential distribution
- $r, z$ , cylindrical coordinates
- $k_0$ , field curvature constant;
- $R_m$ , characteristic radius (trapped ions must have  $r < R_m$ )
- $C$ , constant potential offset

# Establishing rotational and axial oscillation

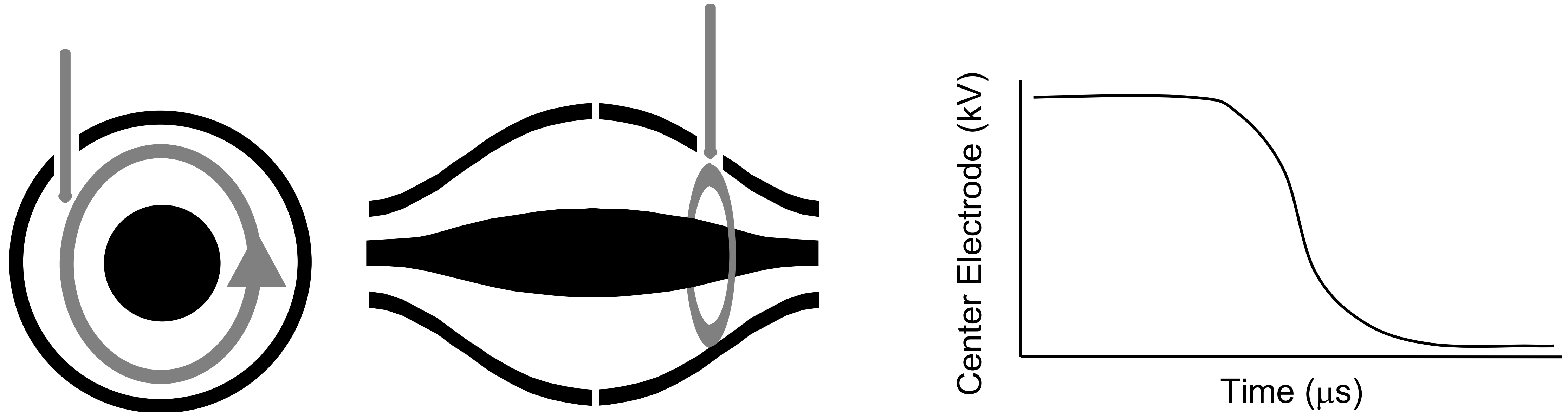

- Ions are rapidly injected as a spatially confined packet at one end of the z axis.
- The center electrode potential is lowered in order to trap the ions in a stable orbit.
- The ions of a given  $m/z$  thus begin their z-axis oscillation with the same phase.

# Different oscillation frequencies

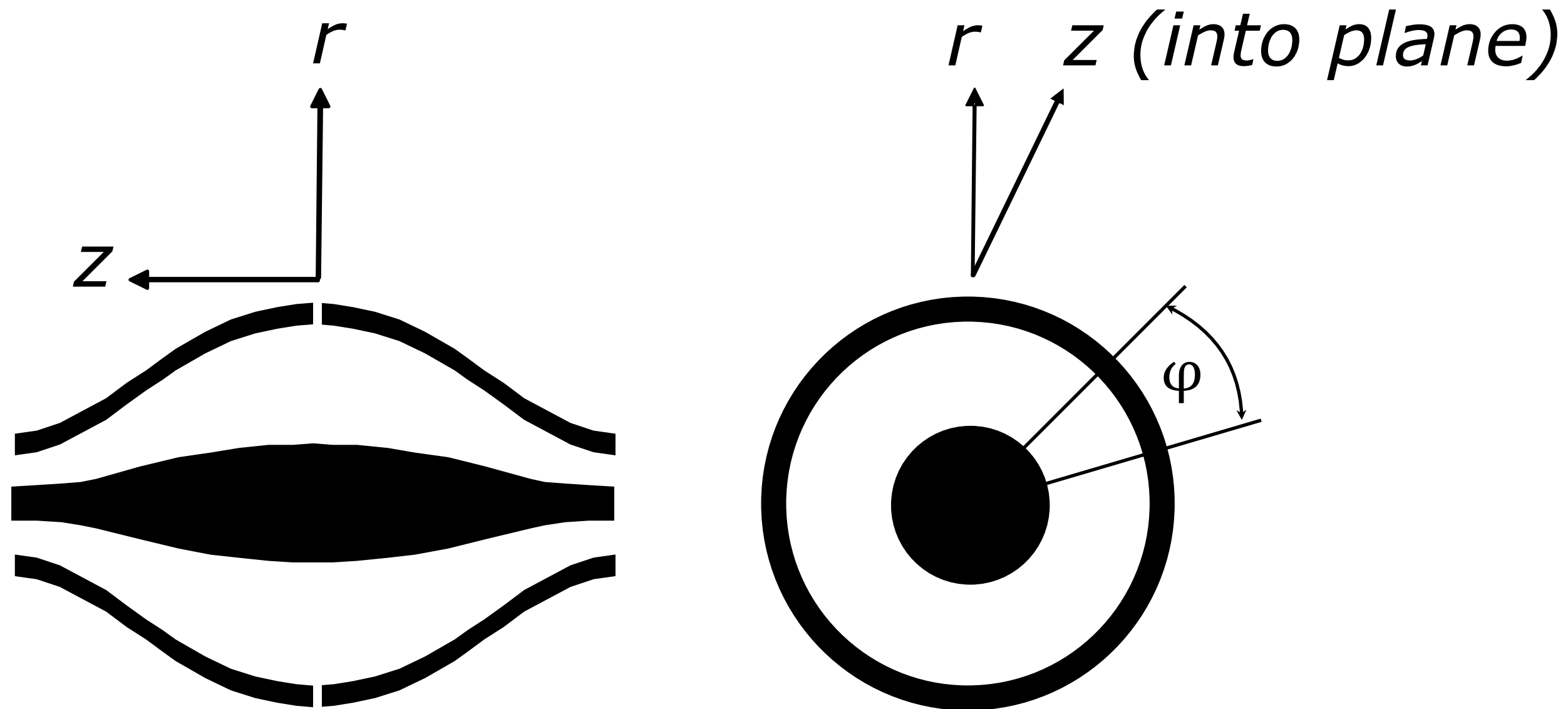

$$R = \frac{m}{\Delta m};$$

**Resolution:**

$$m \propto \frac{1}{\omega_z^2}; \quad dm \propto \left(\frac{1}{\omega_z^2}\right)' d\omega = \frac{-2}{\omega_z^3} d\omega;$$

$$\frac{m}{\Delta m} \propto \frac{1}{\omega_z^2} \frac{\omega_z^3}{\Delta\omega} \propto \omega_z \cdot t \propto \frac{t}{\sqrt{m}}.$$

– Frequency of radial oscillations:  $\omega_r = \omega_z \sqrt{\left(\frac{R_m}{R}\right)^2 - 2}$

– Frequency of rotation:  $\omega_\varphi = \frac{\omega_z}{\sqrt{2}} \sqrt{\left(\frac{R_m}{R}\right)^2 - 1}$

– Frequency of axial motion:  $\omega_z = \sqrt{\frac{k_0 z e}{m}}$

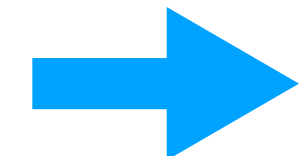

$$\frac{m}{z} = \frac{k_0 e}{4\pi^2 f_z^2}$$

Only this motion depends on m/z !

- ✓ Resolution decreases with m as  $m^{-1/2}$
- ✓ Resolution increases with time of measurements

# Orbitrap ion current detection

- Similar to FT ICR;
- Frequency of axial oscillations

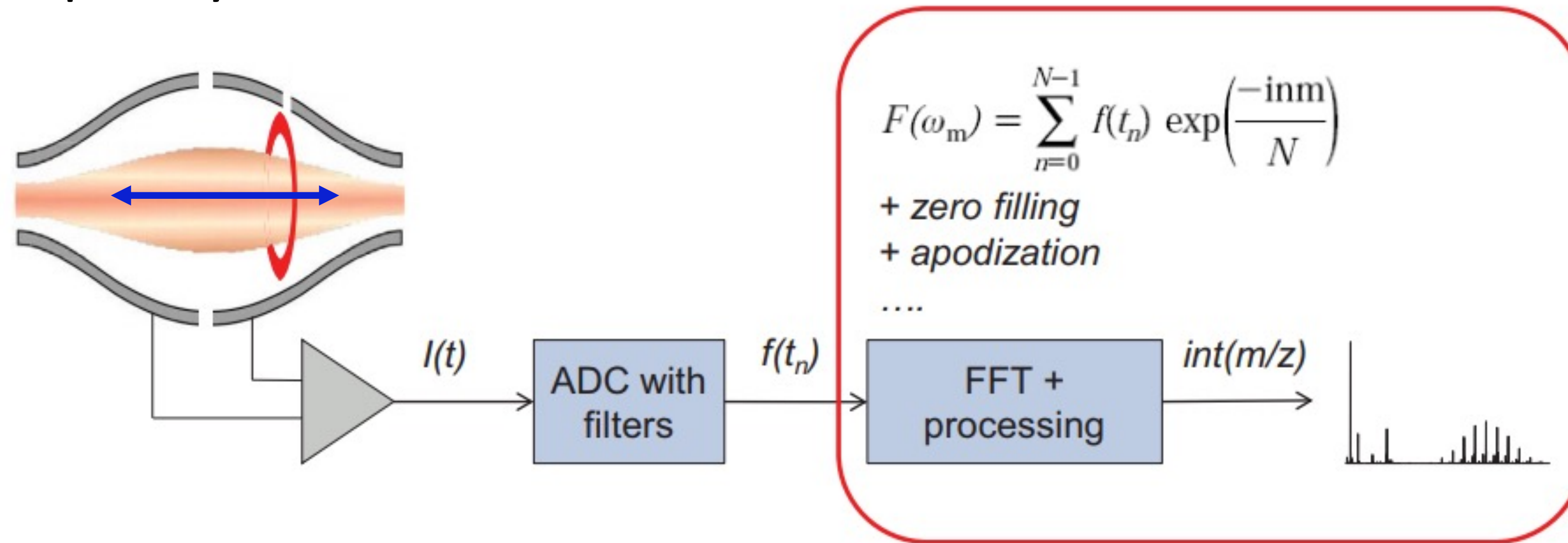

The image current on each half is differentially amplified and undergoes Analog-to-Digital Conversion before FT algorithm

- Fourier Transform is used to convert signal to  $m/z$  data

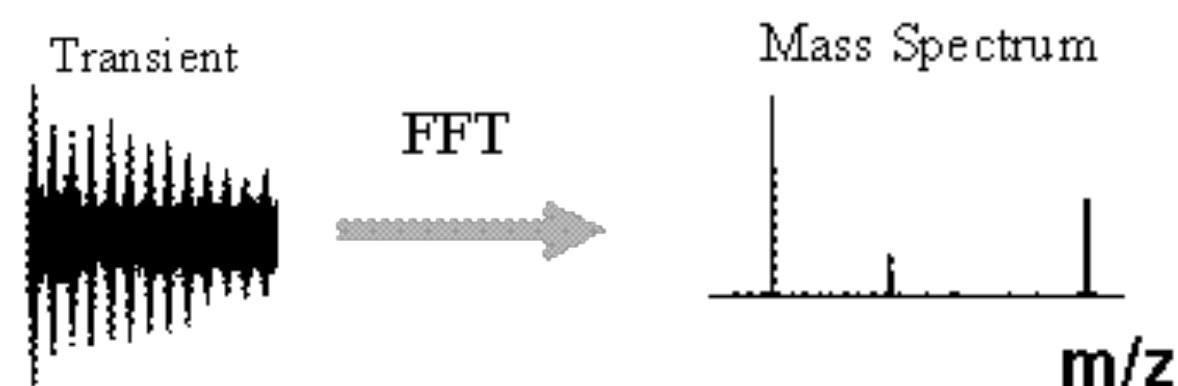

Details of FT will be given in NMR section

# Orbitrap summary

- + High performance instrument competitive with FT-ICR mass analyzers
- + Mass resolving power up to 240'000 at 400  $m/z$
- + Resolution depends on the transient length: 512 ms for 240K on a Q-Exactive HF.
- + High mass accuracy (1 ppm).
- + Compare with ICR: compact: no LHe is required; low cost; low operation cost.
- Requires ultra-high vacuum to realize sufficiently long transients
- Resolving power is directly linked to scan speed (lower scan speed yields better RP)
- RP decreases with increasing  $m/z$

# Fragmentation methods and tandem mass spectrometry

# Tandem mass spectrometry

Problem: How do you distinguish two different molecules of exactly the same mass?

Break them into pieces and analyze the mass of the pieces

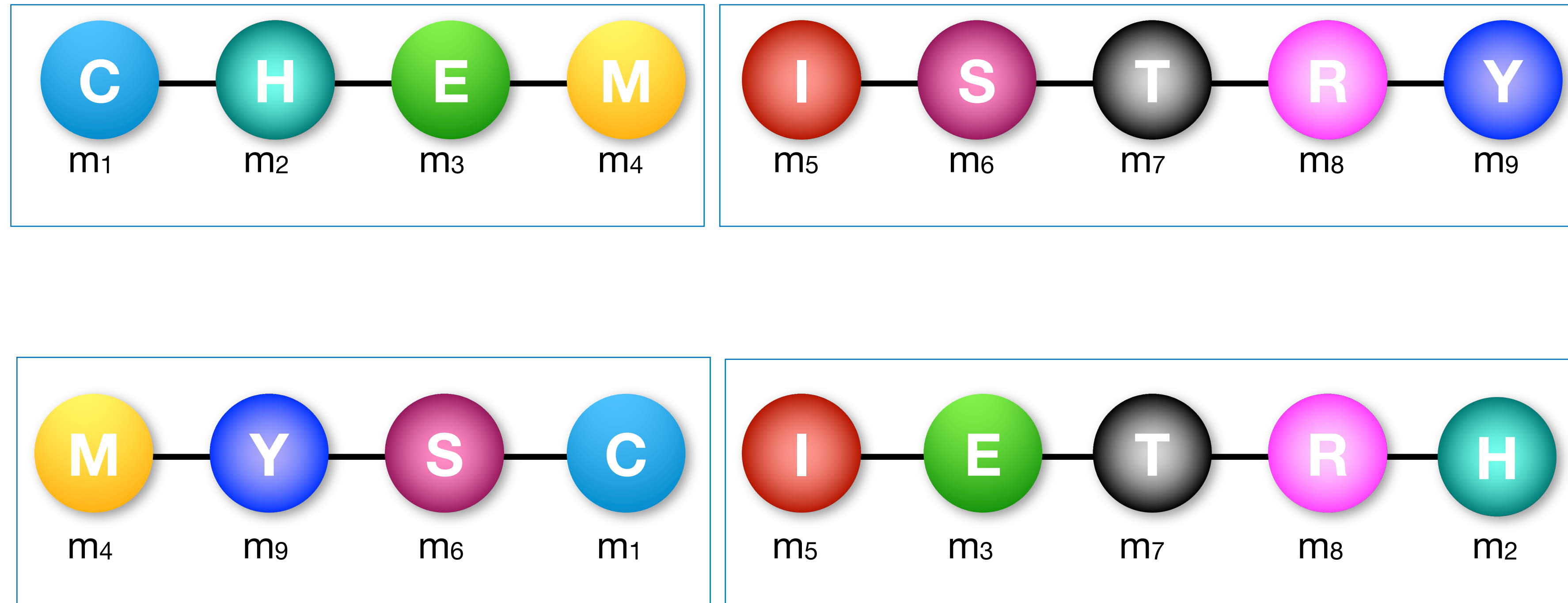

In general, the pieces will have different mass.

# Tandem mass spectrometry

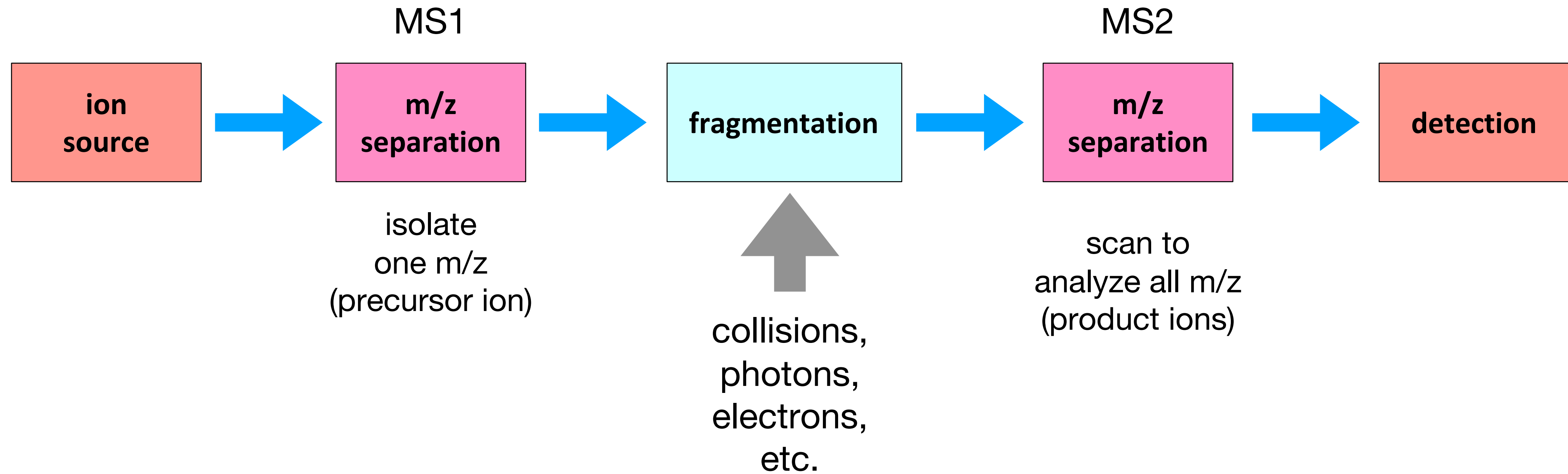

# Fragmentation methods in tandem MS

- Collision Induced Dissociation (CID)
  - Low-energy CID
  - High-energy CID (HCD)
- Surface-induced Dissociation (SID)
- Photodissociation
  - Infrared Multi-photon Dissociation (IRMPD)
  - UV Photodissociation (UVPD)
- Electron Capture Dissociation (ECD)
- Electron Transfer Dissociation (ETD)

Different fragmentation techniques produce different types of fragments, which is useful for structural analysis.

Different MS techniques are best suited to specific fragmentation methods.

# Collision-induced dissociation (CID)

**Low energy:** Energy deposited into a molecule slowly through multiple, low-energy collisions.

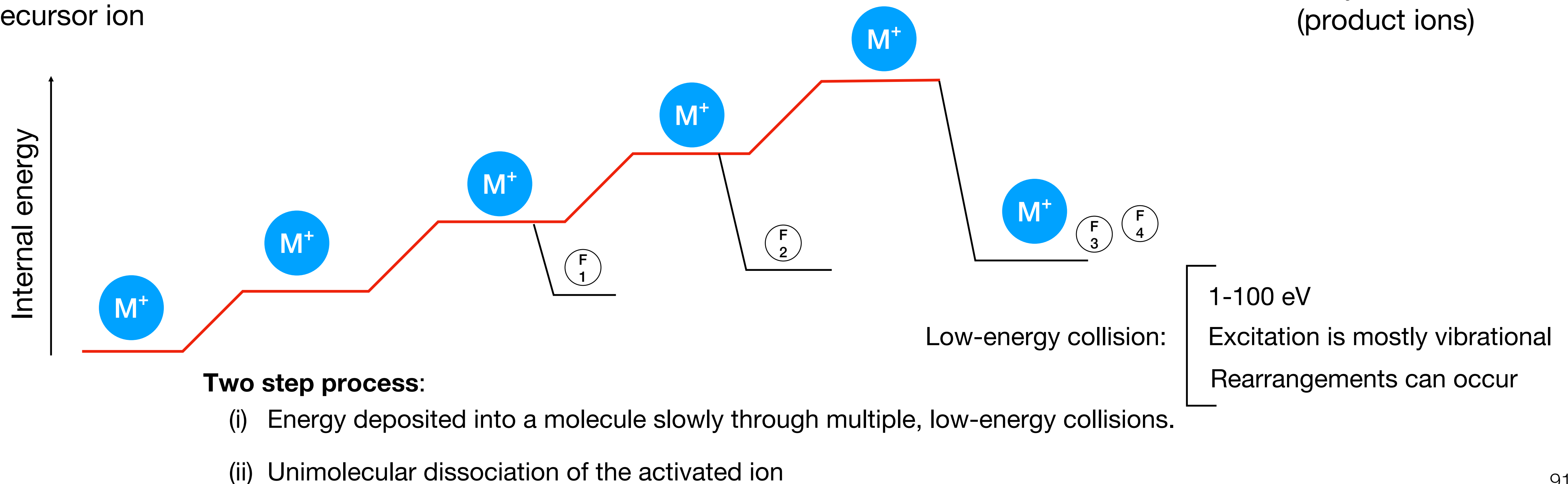
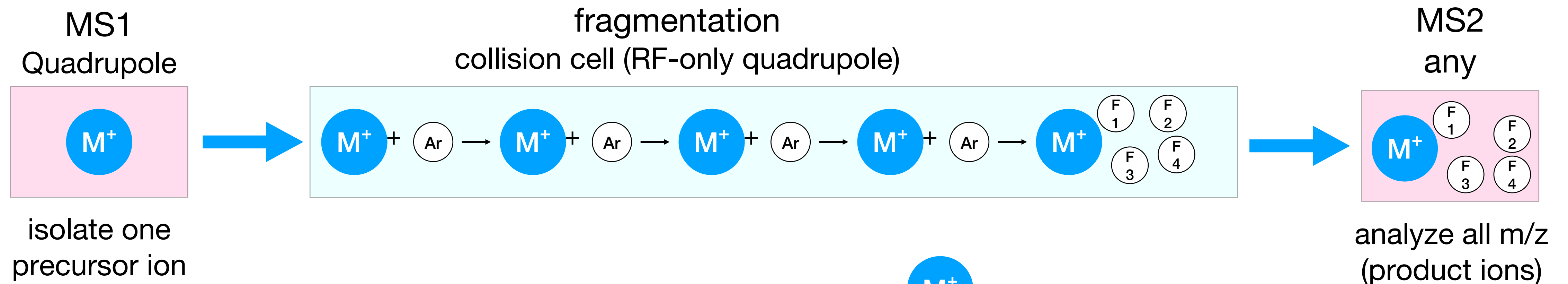

# Electron capture dissociation (ECD)

- ECD involves the capture of low-energy electrons by multiply charged ions, with charge-state reduction and subsequent fragmentation
- Works in FTICR but it is difficult to perform in quadrupole traps, orbitraps, . . .

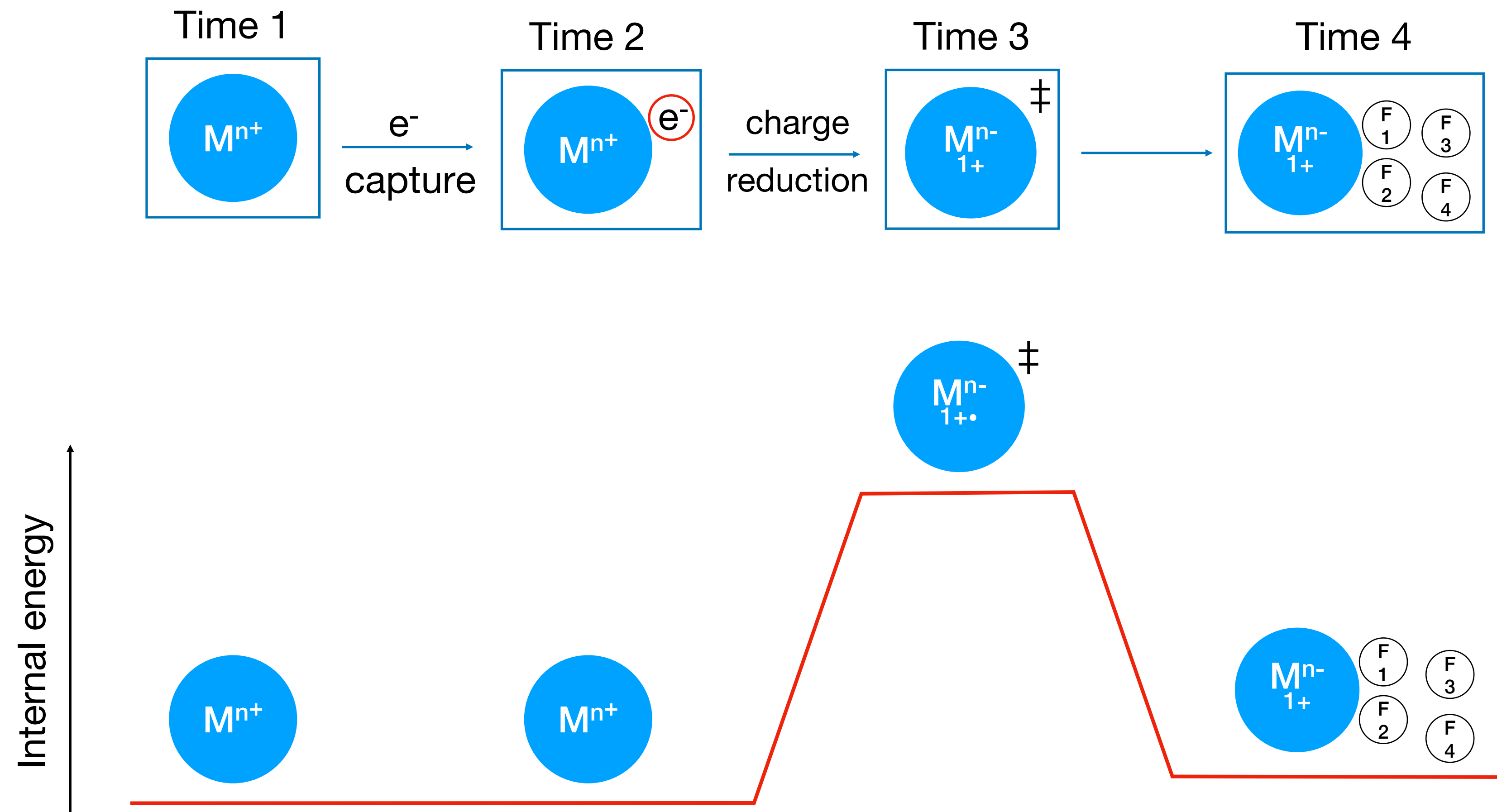

# Photon-induced dissociation

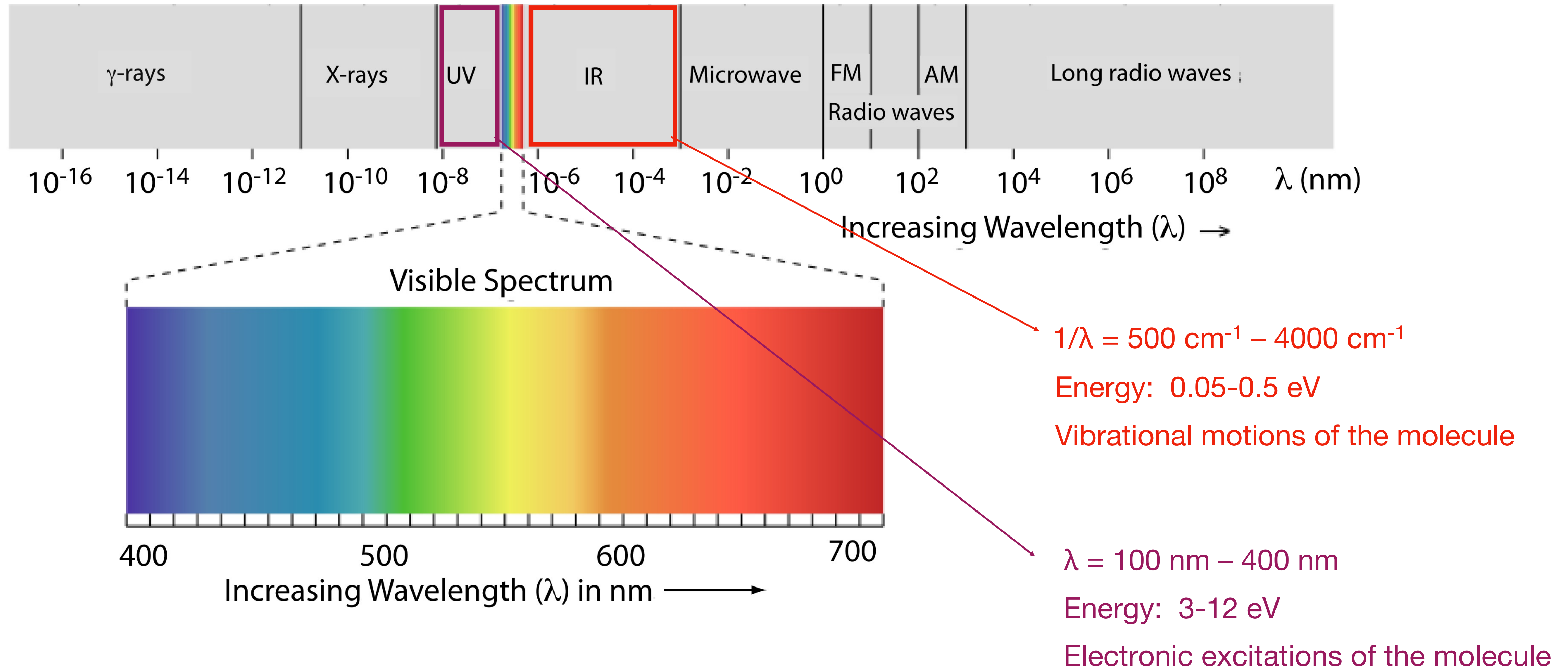

# Infrared multiphoton dissociation (IRMPD)

- Involves excitation of multiple IR photons by IR active modes
- After photon absorption, rapid redistribution of energy over all vibrational degrees of freedom occurs.
- Statistical internal energy distribution (like in CID)

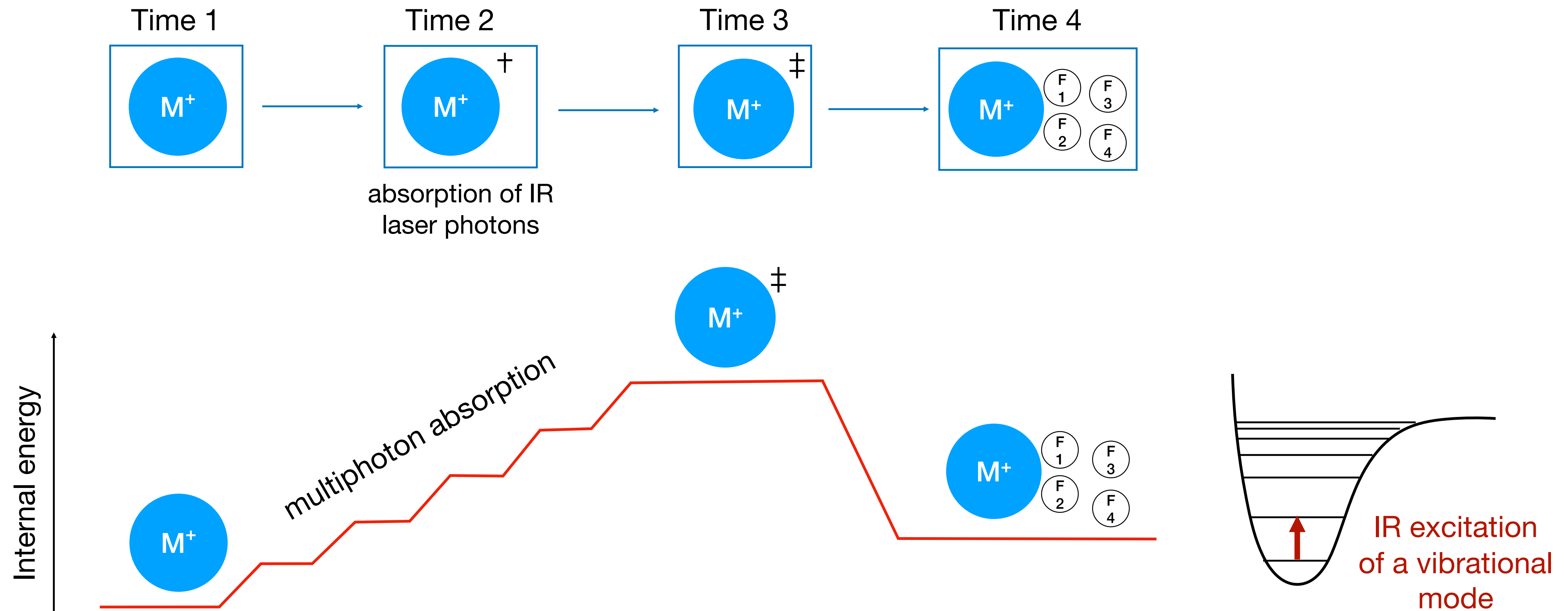

# UV photodissociation (UVPD)

- Activation occurs through the absorption of a single UV photon
- The photon causes a vibronic transition, which is a simultaneous change both in electronic and vibrational state

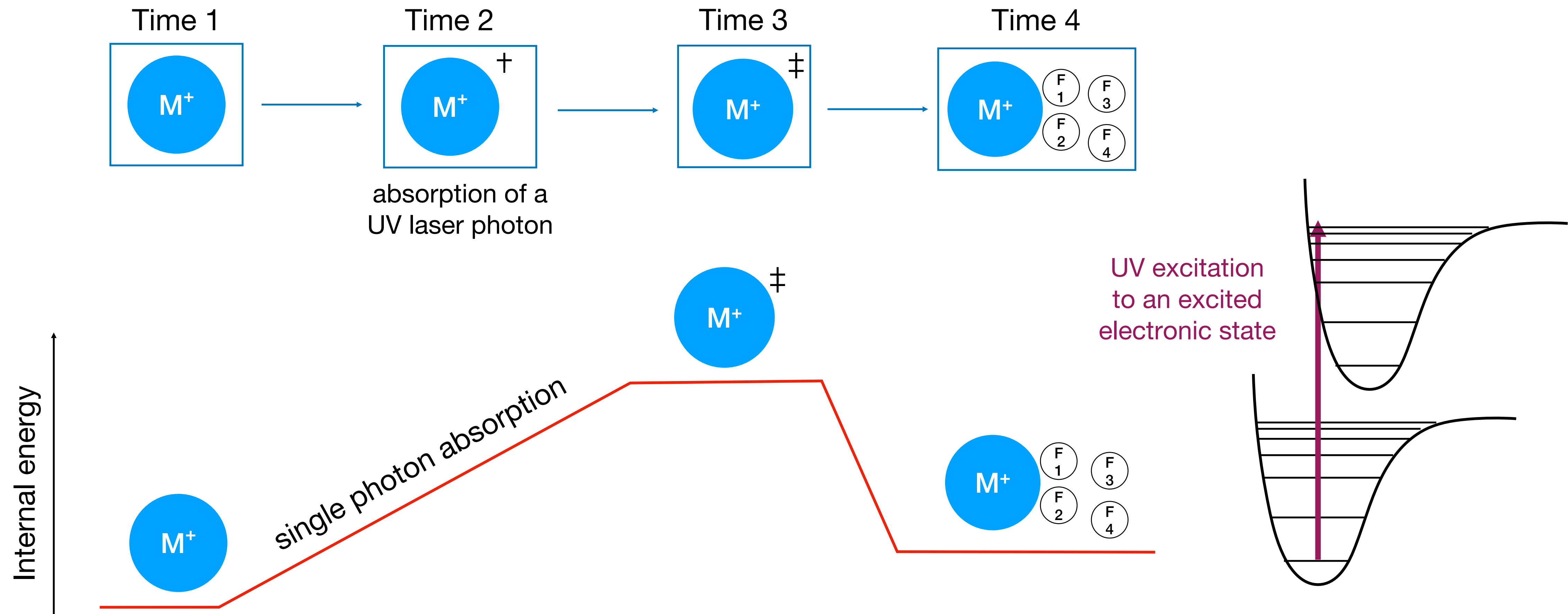

+

## Comparison of fragmentation methods

-

Simple Large diversity of fragments Applicable to any charge state	<b>CID</b>	Unpredictable fragments Loss of PTMs No info on 3D structure
Similar to CID; Retains some PTMs;	<b>HCD</b>	Unpredictable fragmentation Loss of high fraction of PTMs No info on 3D structure
Similar to CID, but doesn't require collisions; Can be wavelength selective;	<b>IRMPD</b>	The same as for CID; Technical complexity
Non-statistical, gives specific fragments; Retains PTMs, reflects 3D structure + Highly specific to ions/isomers	<b>UVPD</b> <b>UVPD-MS</b>	Technical complexity Moderate dissociation yield Additional technical complexity
Cleaves very wide types of bonds; High fragment abundance; Retains some PTMs;	<b>VUVPD</b>	Technical complexity; No info on 3D structure
Non-statistical, highly predictable bond cleavage (c, z fragments); Retains most of PTMs	<b>ETD/ECD</b>	Low efficiency; Not applicable to singly-charged and negative ions; Very limited info on 3D structure

# Peptide structure

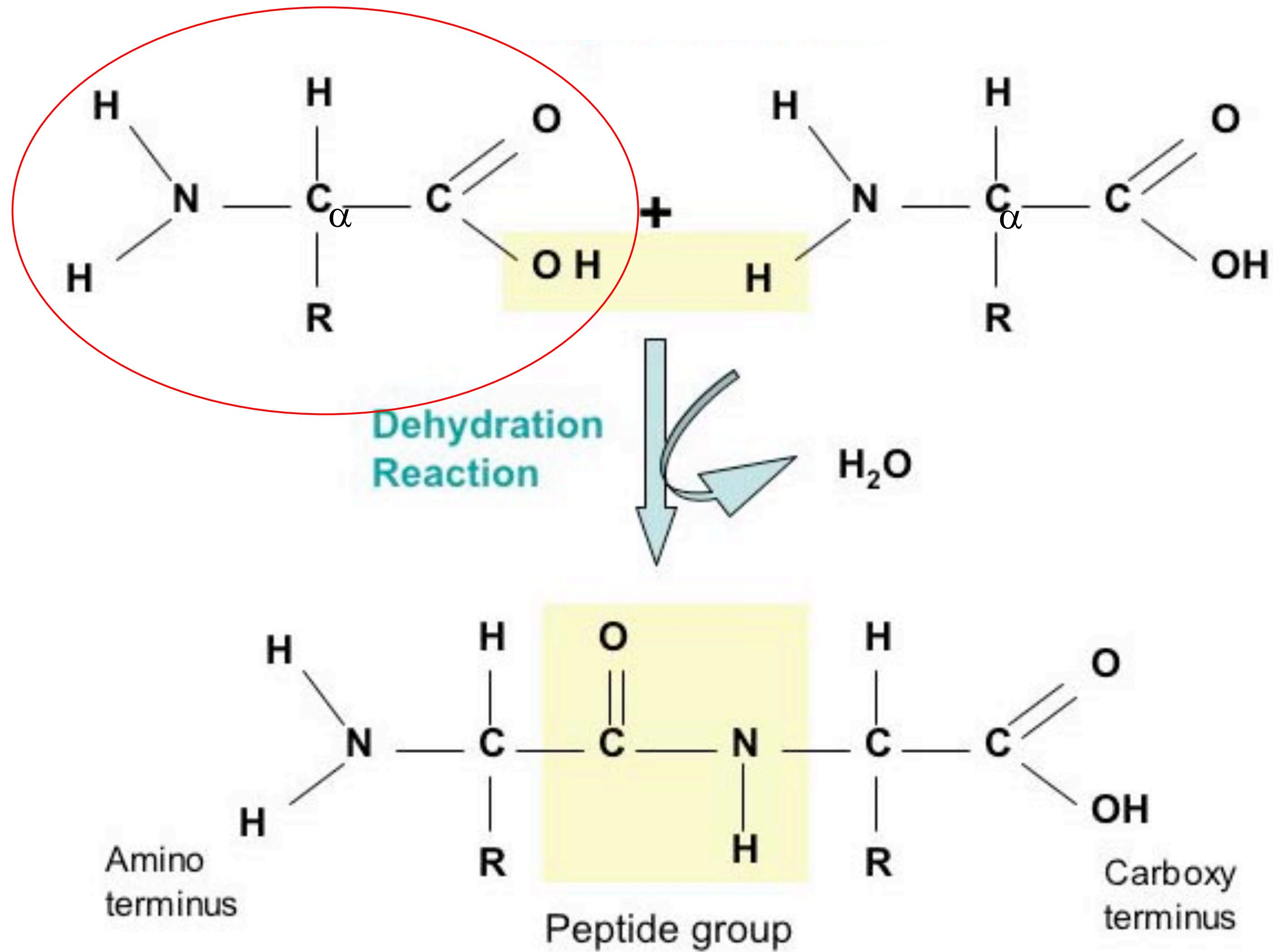

# Tandem MS of peptides and proteins

## Nomenclature for peptide fragments:

For x, y, and z fragments, the charge remains on the fragment to the right.

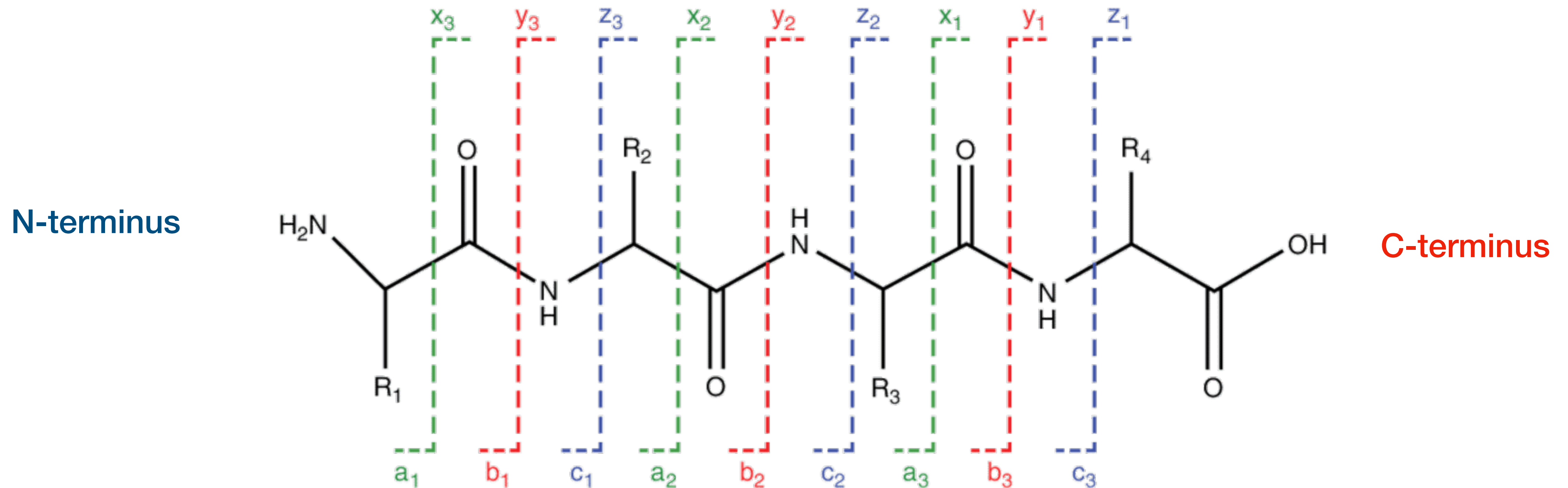

For a, b, and c fragments, the charge remains on the fragment to the left

# Peptide fragmentation

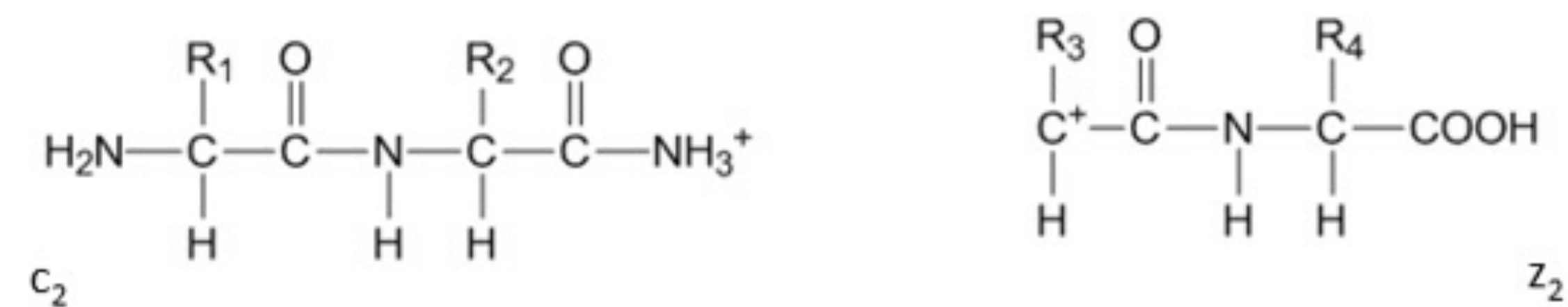
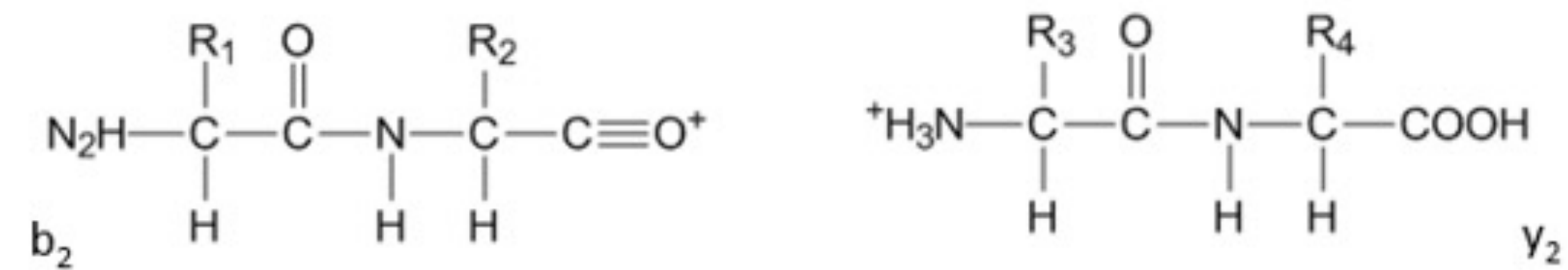
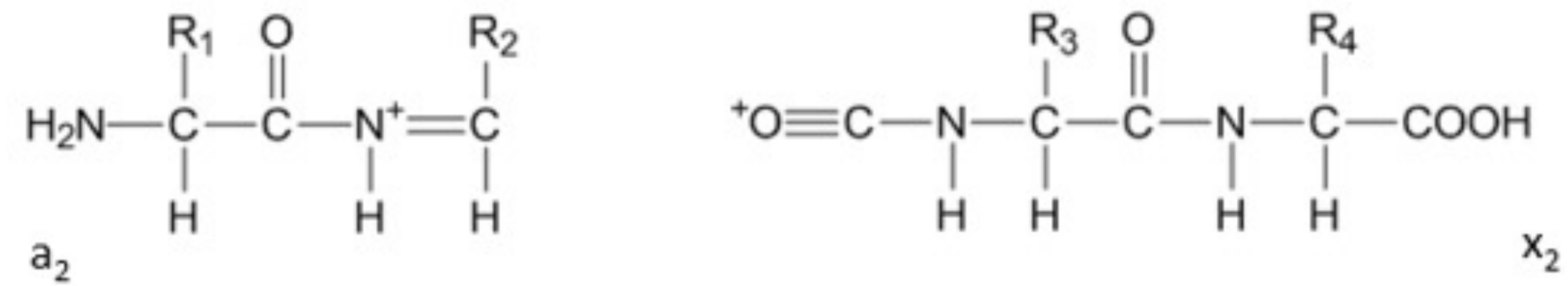
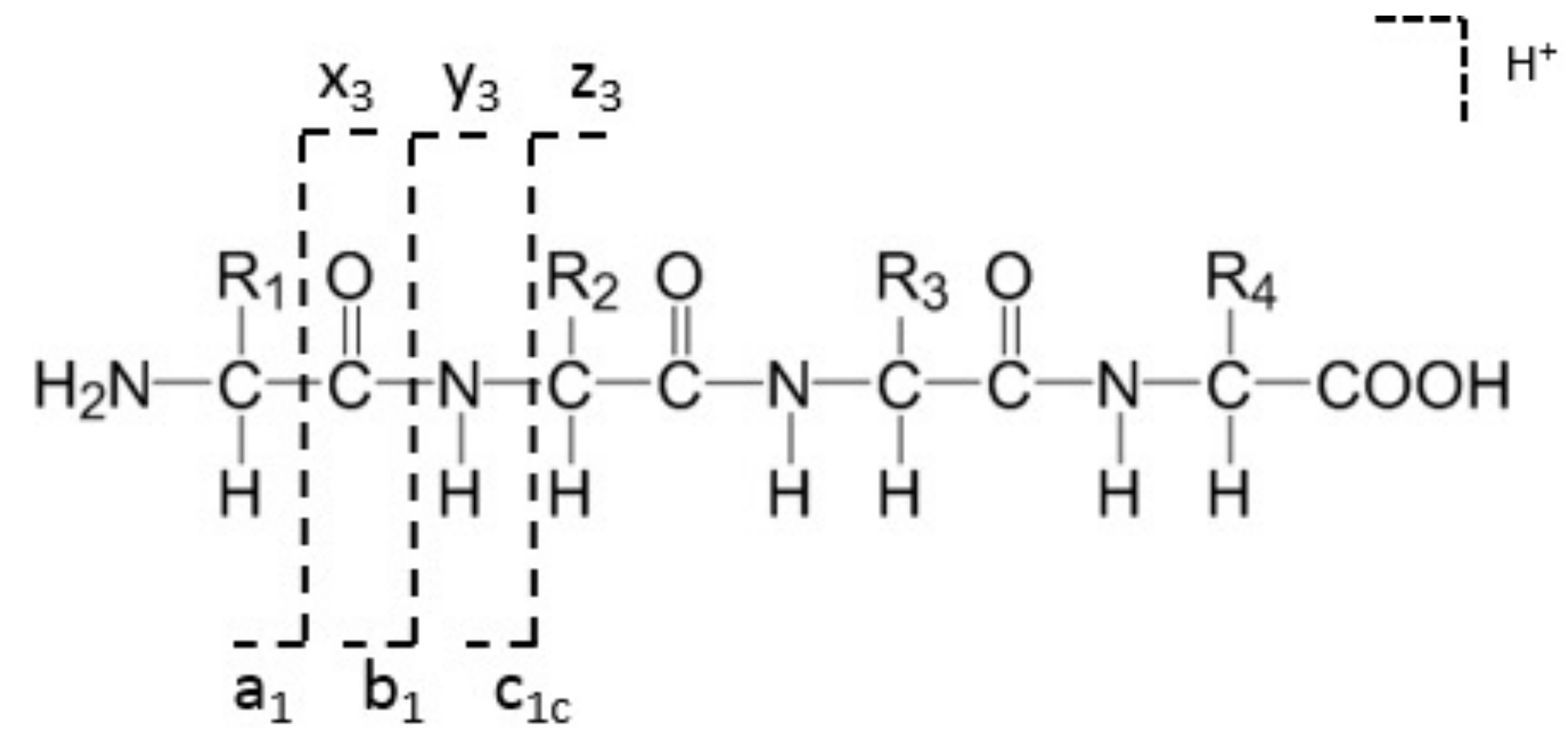

# Peptide fragmentation

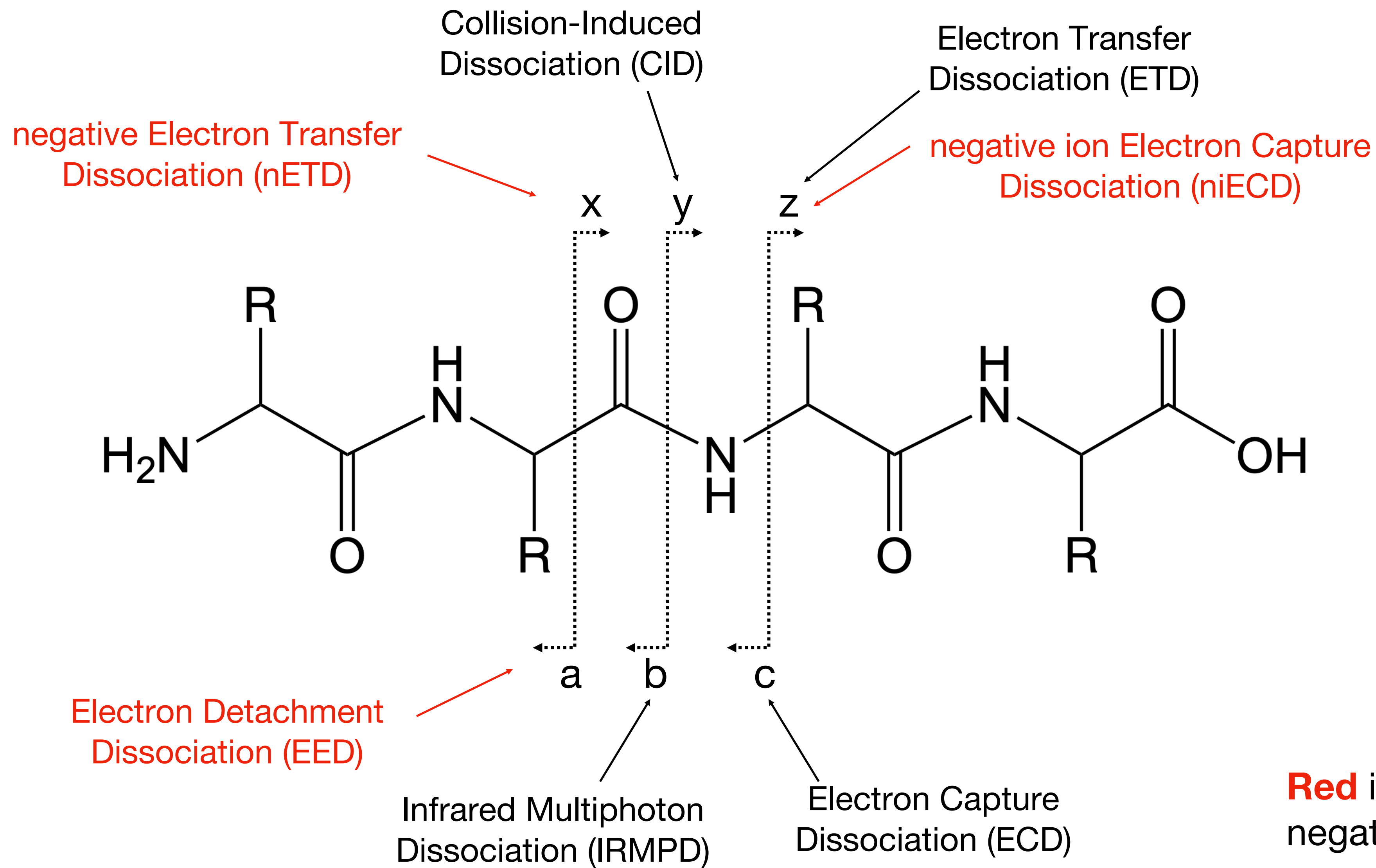

# How to calculate b/y fragments

$b_n$

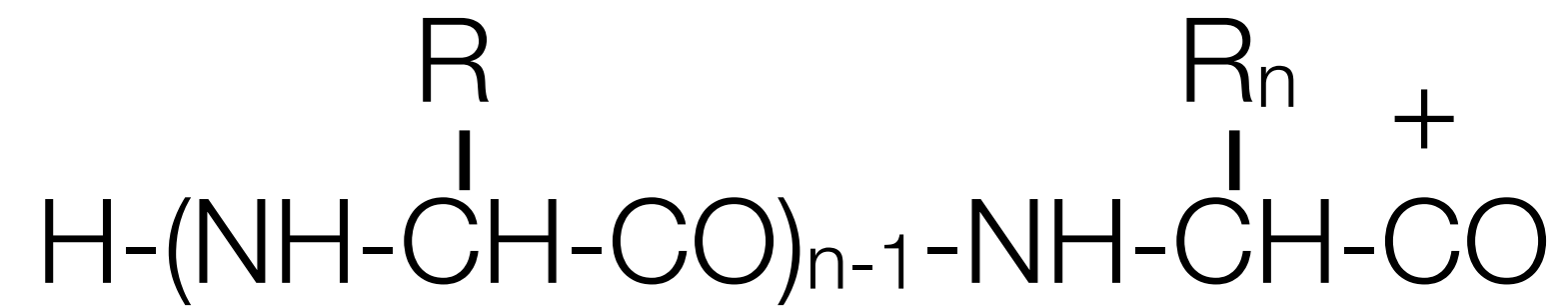

$$\begin{aligned} m(b_n) &= \\ &= \sum_{i=1}^{n-1} m(R_i + C_2H_2NO) + \\ &+ m(R_n) + m(C_2H_3NO^+) \end{aligned}$$

Enumeration starts from N-terminus

$y_n$

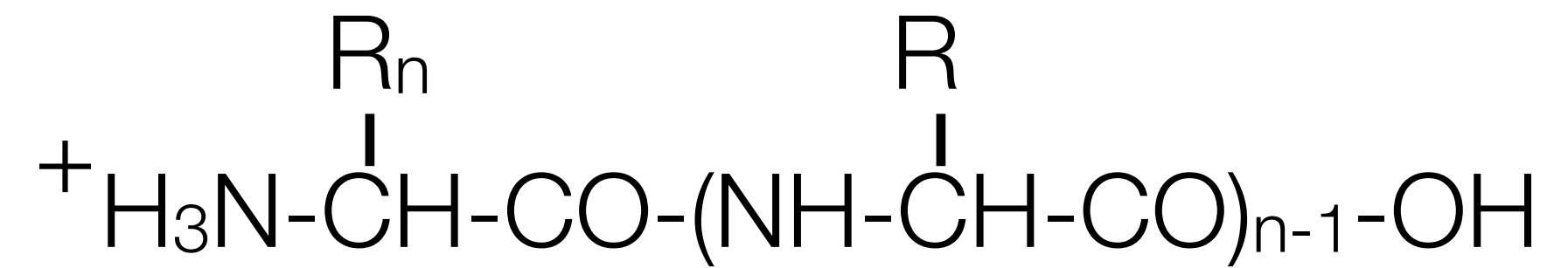

$$\begin{aligned} m(y_n) &= \\ &= \sum_{i=1}^{n-1} m(R_i + C_2H_2NO) + \\ &+ m(R_n) + m(C_2H_5NO_2^+) \end{aligned}$$

Enumeration starts from C-terminus

*Hydrogen jumps to y-side*